

REV	DESCRIPTION	DATE
A	INITIAL RELEASE	21-08-2024

_____ NEW WIRE / UNIT
 - - - - - EXISTING WIRE / UNIT

NOTES:

- PERFORM ALL WORK IN ACCORDANCE WITH BELL HELICOPTERS STANDARD PRACTICES MANUAL BHT-ELEC-SPM.
- ALL NEW UNSHIELDED WIRE USE M22759/41-(XX)-9 OR EQUIVALENT TYPE WIRE. (M22759/41-(XX)-9 IS NOT INTENDED TO BE USED IN SOLDER APPLICATIONS, SOLDERABILITY CAN BE ACHIEVED WITH THE PROPER SOLDER. USE CRIMP SPLICES FOR REPAIR). ALL WIRES 22 AWG UNLESS OTHERWISE SPECIFIED BY WIRE CODE. ALL JUMPERS TO BE LESS THAN 6 INCHES.
- ALL NEW SHIELDED WIRE USE M27500-(XX)SM(X)N23 OR EQUIVALENT TYPE WIRE. (M27500-(XX)SM(X)N23 IS NOT INTENDED TO BE USED IN SOLDER APPLICATIONS, SOLDERABILITY CAN BE ACHIEVED WITH THE PROPER SOLDER. USE CRIMP SPLICES FOR REPAIR). SOLDER SLEEVES SHALL USE SN96 SOLDER, USE P/N S200-X-00 OR EQUIVALENT.
- ALL AIRFRAME GROUNDS SHALL BE VIA LUG OR GROUNDING BLOCK AND PROVIDE SEPARATE GROUND STUD LOCATIONS FOR DC POWER GROUNDS, AC POWER GROUNDS, CHASSIS GROUNDS, SIGNAL GROUNDS AND SHIELD GROUNDS.
- ALL EQUIPMENT BONDING TO ADJACENT AIRFRAME STRUCTURE TO BE 0.003 OHM OR LESS. ALL ELECTRICAL GROUNDING AND BONDING TO BE INSTALLED IN ACCORDANCE WITH THE LATEST REVISION OF BHT-ELEC-SPM CHAPTER 8.
- ALL TERMINALS TO BE INSTALLED IN ACCORDANCE WITH THE LATEST REVISION OF BHT-ELEC-SPM PARAGRAPH 4-9.
- ALL CONNECTORS TO BE INSTALLED IN ACCORDANCE WITH THE LATEST REVISION OF BHT-ELEC-SPM CHAPTER 5. ENSURE ALL UNUSED CONNECTOR CONTACTS ARE FILLED WITH SPARE PINS/SOCKETS OR PLASTIC GROMMET SEALING PLUGS. ENSURE ALL BULKHEAD MOUNTED CONNECTORS ARE PROPERLY BONDED TO AIRFRAME.
- ENSURE ALL SWITCHES, CIRCUIT BREAKERS, AND REMOTE MOUNTED BOXES ARE LABELED WITH A CONSISTENT SIZE, FONT, COLOR, BACKGROUND AND ARE ILLUMINATED CONSISTENT AS EXISTING LABELS.
- ROUTE ALL WIRES AND CABLES WITH EXISTING WIRE ROUTES WHERE POSSIBLE AND CLAMP IN ACCORDANCE WITH THE LATEST REVISION OF BHT-ELEC-SPM CHAPTER 6. WIRES MUST BE ROUTED WITH A MINIMUM OF 6 INCHES OF SEPARATION FROM OXYGEN AND FLUID LINES (MIN 2 INCHES IF WIRES IN CONDUIT).

PART NUMBER	DESCRIPTION	REMARKS
-011	FUEL QUANTITY INDICATOR SYSTEM	

PREPARED	NF
REVIEWED	CP
RELEASED	JP
SCALE:	NTS



COPYRIGHT ©2024 BY EAGLE COPTERS MAINTENANCE LTD
 THIS DOCUMENT IS PRIVATE AND CONFIDENTIAL AND IS SUPPLIED ON THE EXPRESS CONDITION THAT IT IS NOT TO BE USED FOR ANY PURPOSE OR COPIED OR COMMUNICATED TO ANY OTHER PERSON WITHOUT WRITTEN PERMISSION FROM EAGLE COPTERS MAINTENANCE LTD.

TITLE:		DWG:	
WIRING DIAGRAM		E212-9046	
FUEL SYSTEM		REV:	SHEET:
EAGLE SINGLE, B212		A	1 OF 2

THIS DRAWING IS UNCONTROLLED UNLESS OPENED DIRECTLY FROM ECML'S CONTROLLED REPOSITORY

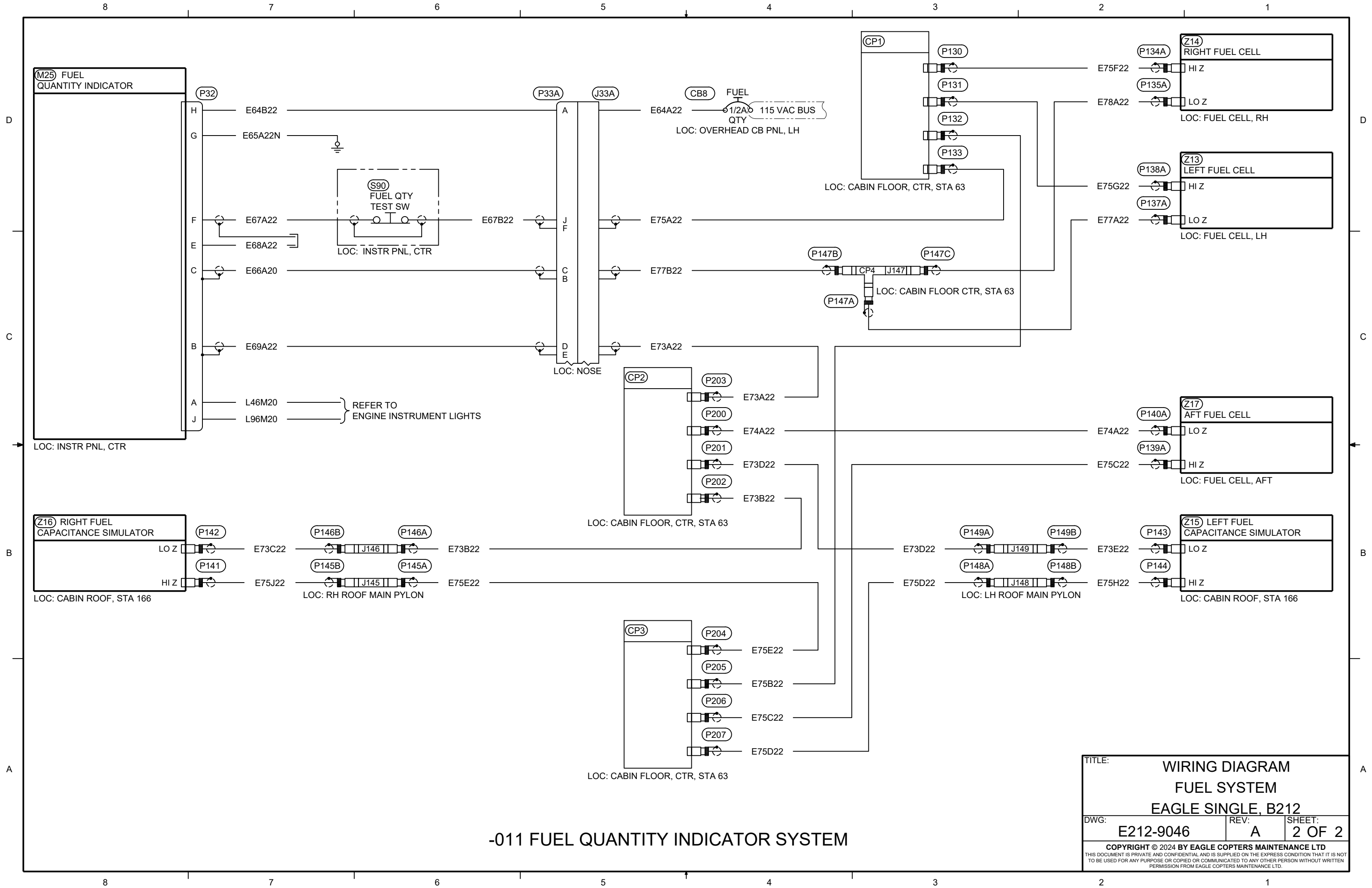

-011 FUEL QUANTITY INDICATOR SYSTEM

TITLE:		
WIRING DIAGRAM FUEL SYSTEM EAGLE SINGLE, B212		
DWG:	REV:	SHEET:
E212-9046	A	2 OF 2
<small>COPYRIGHT © 2024 BY EAGLE COPTERS MAINTENANCE LTD THIS DOCUMENT IS PRIVATE AND CONFIDENTIAL AND IS SUPPLIED ON THE EXPRESS CONDITION THAT IT IS NOT TO BE USED FOR ANY PURPOSE OR COPIED OR COMMUNICATED TO ANY OTHER PERSON WITHOUT WRITTEN PERMISSION FROM EAGLE COPTERS MAINTENANCE LTD.</small>		