



Eagle Copters Maintenance Ltd.  
823 McTavish Road NE  
Calgary, Alberta, Canada  
T2E 7G9  
Tel: 1 403 250 7370  
Fax: 1 403 250 7110  
<http://www.eaglecopters.com>

**ROTORCRAFT FLIGHT MANUAL SUPPLEMENT**  
FMS-D212-725-1  
**Eagle Single**  
**Bell 212 Models**  
TCCA STC SH07-28  
FAA STC SR02831NY

Sections 1 – 4 of this document comprise the Approved Flight Manual Supplement. Compliance with Section 1, Limitations is mandatory. Section 5 is unapproved and is provided for information only.



Prepared By: *S. Jayaramareddy*  
S. Jayaramareddy  
Reviewed By: *M. Peters*  
M. Peters

• COPYRIGHT © 2007 BY EAGLE COPTERS MAINTENANCE LTD •

This document is private and confidential and is supplied on the express condition that it is not to be used for any purpose or copied or communicated to any other person without written permission from Eagle Copters Maintenance Ltd.

TCCA Approved

Revision: **M**  
Date: 2026-04-13



This page intentionally left blank

• COPYRIGHT © 2007 BY EAGLE COPTERS MAINTENANCE LTD •

This document is private and confidential and is supplied on the express condition that it is not to be used for any purpose or copied or communicated to any other person without written permission from Eagle Copters Maintenance Ltd.

TCCA Approved

Revision: **M**  
Date: 2026-04-13



## Log of Revisions

|                 |            |                 |            |
|-----------------|------------|-----------------|------------|
| Revision A..... | 2007.06.01 | Revision H..... | 2019.02.15 |
| Revision B..... | 2007.11.30 | Revision I..... | 2019.04.23 |
| Revision C..... | 2008.06.12 | Revision J..... | 2022.01.05 |
| Revision D..... | 2008.12.17 | Revision K..... | 2022.04.27 |
| Revision E..... | 2009.08.10 | Revision L..... | 2023.01.16 |
| Revision F..... | 2010.05.12 | Revision M..... | 2026.04.13 |
| Revision G..... | 2013.08.09 |                 |            |

• COPYRIGHT © 2007 BY EAGLE COPTERS MAINTENANCE LTD •

This document is private and confidential and is supplied on the express condition that it is not to be used for any purpose or copied or communicated to any other person without written permission from Eagle Copters Maintenance Ltd.

TCCA Approved

Revision: **M**  
Date: 2026-04-13



## Revisions

Revised text is indicated by a black vertical line. Insert latest revision pages: dispose of superseded pages.

• COPYRIGHT © 2007 BY EAGLE COPTERS MAINTENANCE LTD •

This document is private and confidential and is supplied on the express condition that it is not to be used for any purpose or copied or communicated to any other person without written permission from Eagle Copters Maintenance Ltd.

TCCA Approved

Revision: **M**  
Date: 2026-04-13



## General Information

This manual is a flight manual supplement (FMS) for the basic Bell 212 Flight Manual, however, unlike most flight manual supplements, all relevant information from the basic Bell 212 Flight Manual has been incorporated into this FMS for the convenience of the pilot. Therefore, there is no need to refer to the basic Bell 212 Flight Manual.

To indicate which sections are original from the Bell 212 Flight Manual and which sections are specific to this Flight Manual Supplement the following indication have been used.

If the section, paragraph or information is reproduced from the Bell 212 Flight Manual, it has an ivory background.

If the section or paragraph is part of the amended information that forms the Flight Manual Supplement it has no special formatting.

Only the material altered/changed/deleted due to the modification is approved by Transport Canada. The remaining material remains FAA approved.

This FMS is required when the aircraft has been modified with the installation of a Honeywell T5317A/B/BCV engine as per TCCA STC SH07-28 / FAA STC SR02831NY and shall be in the helicopter during all operations.

This flight manual is divided into six sections as follows:

- Section 1            Limitations
- Section 2            Normal Procedures
- Section 3            Emergency and Malfunction Procedures
- Section 4            Performance Data
- Section 5            Weight and Balance Data
- Appendix A        Optional Equipment Supplements

Sections 1 through 4 contain Transport Canada approved data necessary to operate the helicopter in a safe and efficient manner.

• COPYRIGHT © 2007 BY EAGLE COPTERS MAINTENANCE LTD •

This document is private and confidential and is supplied on the express condition that it is not to be used for any purpose or copied or communicated to any other person without written permission from Eagle Copters Maintenance Ltd.

Section 5 provides weight and balance data essential for safe operation of the helicopter.

Appendix A provides a list of Optional Equipment Supplements.

The Manufacturer's Data Manual (MD-D212-725-1) consists of additional information to be used in conjunction with the flight manual. This manual contains useful information to familiarize the operator with the helicopter and its systems, to facilitate ground handling and servicing and assist in flight planning and operations.

The Manufacturer's data is divided into three sections:

Section 1 – Systems Description

Section 2 – Handling and Servicing

Section 3 – Conversion Charts and Tables

## Terminology

Warnings, cautions and notes are used throughout this manual to emphasize important and critical instructions and are used as follows:

### WARNING

**AN OPERATING PROCEDURE, PRACTICE ETC., WHICH IF NOT CORRECTLY FOLLOWED, COULD RESULT IN PERSONAL INJURY OR LOSS OF LIFE.**

### CAUTION

**AN OPERATING PROCEDURE, PRACTICE ETC., WHICH, IF NOT STRICTLY OBSERVED, COULD RESULT IN DAMAGE TO OR DESTRUCTION OF EQUIPMENT.**

• COPYRIGHT © 2007 BY EAGLE COPTERS MAINTENANCE LTD •

This document is private and confidential and is supplied on the express condition that it is not to be used for any purpose or copied or communicated to any other person without written permission from Eagle Copters Maintenance Ltd.

## Note

*An operating procedure condition etc., which is essential to highlight.*

## Use of Procedural Words

Procedural word usage and intended meaning which has been adhered to in preparing this manual is as follows:

**SHALL** has been used only when application of a procedure is mandatory

**SHOULD** has been used only when application of a procedure is recommended.

**MAY** and **NEED NOT** have been used only when application of a procedure is optional.

**WILL** has been used only to indicate futurity, never to indicate a mandatory procedure.

Abbreviations and acronyms used throughout this manual are defined as follows:

|                            |                               |
|----------------------------|-------------------------------|
| AC                         | Alternating current           |
| AGL                        | Above Ground Level            |
| ATTD                       | Attitude                      |
| BLWR                       | Blower                        |
| C                          | Celsius                       |
| CG                         | Center of Gravity             |
| DC                         | Direct Current                |
| DECR                       | Decrease                      |
| DSENGA                     | Disengage                     |
| EGT                        | Exhaust Gas Temperature       |
| ELT                        | Emergency Locator Transmitter |
| ENG                        | Engine                        |
| ENGA                       | Engage                        |
| ENG RPM (N <sub>2</sub> )  | Engine Power Turbine RPM      |
| F                          | Fahrenheit                    |
| FT                         | Foot, Feet                    |
| GAS PROD (N <sub>1</sub> ) | Gas Producer RPM              |

• COPYRIGHT © 2007 BY EAGLE COPTERS MAINTENANCE LTD •

This document is private and confidential and is supplied on the express condition that it is not to be used for any purpose or copied or communicated to any other person without written permission from Eagle Copters Maintenance Ltd.

|                |                                      |
|----------------|--------------------------------------|
| GEN            | Generator                            |
| GOV            | Governor                             |
| GW             | Gross Weight                         |
| H <sub>D</sub> | Density Altitude                     |
| H <sub>P</sub> | Pressure Altitude                    |
| HSI            | Horizontal Situation Indicator       |
| HTR            | Heater                               |
| HV             | Height-Velocity                      |
| HYDR SYS       | Hydraulic System                     |
| IGE            | In Ground Effect                     |
| IMC            | Instrument Meteorological Conditions |
| INCR           | Increase                             |
| INV            | Inverter                             |
| KCAS           | Knots Calibrated Airspeed            |
| KG             | Kilogram(s)                          |
| KIAS           | Knots Indicated Airspeed             |
| LB             | Pound(s)                             |
| M              | Meter(s)                             |
| MGT            | Measured Gas Temperature             |
| MCP            | Maximum Continuous Power             |
| MIN            | Minimum, Minutes(s)                  |
| NAV            | Navigation                           |
| NON ESS        | Non Essential                        |
| NORM           | Normal                               |
| N <sub>1</sub> | Gas Producer rpm                     |
| N <sub>2</sub> | Power Turbine rpm                    |
| N <sub>R</sub> | Main Rotor rpm                       |
| OAT            | Outside Air Temperature              |
| OGE            | Out of Ground Effect                 |
| PART SEP       | Particle Separator                   |
| PLT            | Pilot                                |
| PRI            | Primary                              |
| REL            | Release                              |
| RPM            | Revolutions per Minute               |
| STA            | Station                              |
| TEMP CONT      | Temperature Control                  |

• COPYRIGHT © 2007 BY EAGLE COPTERS MAINTENANCE LTD •

This document is private and confidential and is supplied on the express condition that it is not to be used for any purpose or copied or communicated to any other person without written permission from Eagle Copters Maintenance Ltd.



|                  |                                  |
|------------------|----------------------------------|
| V <sub>CAL</sub> | Calibrate Airspeed               |
| V <sub>FR</sub>  | Visual Flight Rules              |
| V <sub>G</sub>   | Vertical Gyro                    |
| V <sub>IAS</sub> | Indicated Airspeed               |
| V <sub>MC</sub>  | Visual Meteorological Conditions |
| V <sub>NE</sub>  | Never Exceed Speed               |

• COPYRIGHT © 2007 BY EAGLE COPTERS MAINTENANCE LTD •

This document is private and confidential and is supplied on the express condition that it is not to be used for any purpose or copied or communicated to any other person without written permission from Eagle Copters Maintenance Ltd.

TCCA Approved

Revision: **M**  
Date: 2026-04-13

# Section 1

## Limitations

### Table of Contents

|         |   |      |
|---------|---|------|
| 1.1     | Introduction.....                           | 1-4  |
| 1.2     | Basis of Certification .....                | 1-4  |
| 1.3     | Types of Operation.....                     | 1-4  |
| 1.4     | Flight Crew .....                           | 1-5  |
| 1.5     | Configuration.....                          | 1-5  |
| 1.5.1   | Required Equipment.....                     | 1-5  |
| 1.5.2   | Optional Equipment.....                     | 1-5  |
| 1.5.2.1 | Dual Digital Clocks with USB Chargers ..... | 1-5  |
| 1.5.3   | Doors Open/Removed .....                    | 1-6  |
| 1.5.4   | Passengers .....                            | 1-8  |
| 1.5.5   | Cargo.....                                  | 1-10 |
| 1.5.5.1 | Internal Cargo Configuration .....          | 1-10 |
| 1.5.5.2 | Cargo Compartment.....                      | 1-10 |
| 1.6     | Weight and Center of Gravity.....           | 1-11 |
| 1.6.1   | Weight .....                                | 1-11 |
| 1.6.2   | Center of Gravity .....                     | 1-12 |
| 1.6.2.1 | Longitudinal Center of Gravity.....         | 1-12 |
| 1.6.2.2 | Lateral Center of Gravity .....             | 1-13 |
| 1.7     | Airspeed .....                              | 1-13 |
| 1.8     | Altitude .....                              | 1-15 |
| 1.9     | Maneuvering.....                            | 1-15 |
| 1.9.1   | Prohibited Maneuvers .....                  | 1-15 |
| 1.9.2   | Climb and Descent.....                      | 1-15 |
| 1.9.3   | Slope Landings.....                         | 1-15 |
| 1.10    | Power Limits for Take Off.....              | 1-16 |
| 1.11    | Ambient Temperature .....                   | 1-18 |
| 1.12    | Electrical.....                             | 1-19 |
| 1.12.1  | Battery .....                               | 1-19 |
| 1.12.2  | Ground Power Unit.....                      | 1-19 |

• COPYRIGHT © 2007 BY EAGLE COPTERS MAINTENANCE LTD •

This document is private and confidential and is supplied on the express condition that it is not to be used for any purpose or copied or communicated to any other person without written permission from Eagle Copters Maintenance Ltd.

Revision: **M**

Date: 2026-04-13

TCCA Approved



- 1.12.3 Starter..... 1-19
- 1.12.4 Loadmeter ..... 1-20
- 1.13 Power Plant..... 1-20
  - 1.13.1 Gas Producer (N<sub>1</sub>) RPM..... 1-20
  - 1.13.2 Power Turbine (N<sub>2</sub>) RPM..... 1-21
  - 1.13.3 Torquemeter Pressure (%)..... 1-21
  - 1.13.4 Exhaust Gas Temperature vs OAT Limitations  
(T5317A Only) ..... 1-21
  - 1.13.5 Measured Gas Temp (T5317B/BCV Only) ..... 1-22
  - 1.13.6 Fuel Pressure ..... 1-22
  - 1.13.7 Oil Pressure – Engine ..... 1-23
  - 1.13.8 Oil Temperature – Engine ..... 1-23
- 1.14 Transmission..... 1-23
  - 1.14.1 Transmission Oil Pressure ..... 1-23
  - 1.14.2 Transmission Oil Temperature ..... 1-23
- 1.15 Rotor..... 1-24
  - 1.15.1 Rotor RPM (N<sub>R</sub>) – Power On..... 1-24
  - 1.15.2 Rotor RPM (N<sub>R</sub>) – Power Off..... 1-24
- 1.16 Hydraulic ..... 1-24
  - 1.16.1 Hydraulic Oil ..... 1-24
  - 1.16.2 Hydraulic Pressure ..... 1-24
  - 1.16.3 Hydraulic Temperature..... 1-25
- 1.17 Fuel and Oil..... 1-25
  - 1.17.1 Fuel ..... 1-25
  - 1.17.2 Anti-Icing Additive..... 1-25
  - 1.17.3 Oil – Engine..... 1-26
  - 1.17.4 Oil – Transmission, Intermediate and Tail Rotor Gearboxes..... 1-26
- 1.18 Rotor Brake ..... 1-26
- 1.19 Heater..... 1-26
- 1.20 Additional Placards ..... 1-27
- 1.21 Instrument Markings..... 1-28

• COPYRIGHT © 2007 BY EAGLE COPTERS MAINTENANCE LTD •

This document is private and confidential and is supplied on the express condition that it is not to be used for any purpose or copied or communicated to any other person without written permission from Eagle Copters Maintenance Ltd.

Revision: **M**

Date: 2026-04-13

TCCA Approved



### List of Figures

Figure 1-1 – Nine-place passenger loading configuration 1 ..... 1-8

Figure 1-2 – Nine-place passenger loading configuration 2 ..... 1-9

Figure 1-3 – Nine-place passenger loading configuration 3 ..... 1-9

Figure 1-4 – Weight-Altitude-Temperature (WAT) Chart ..... 1-11

Figure 1-5 – Gross weight vs Center of Gravity Chart ..... 1-12

Figure 1-6A – V<sub>NE</sub> Placard ..... 1-14

Figure 1-6B – Fuel Capacity Placard ..... 1-14

Figure 1-8 – Power Limits for Takeoff ..... 1-16

Figure 1-9A – Pressure Altitude vs Ambient Air Temperature Chart  
(For S/N 30687, 30817, 30599) ..... 1-18

Figure 1-9B – Pressure vs Ambient Air Temperature Chart  
(For all other S/N) ..... 1-19

Figure 1-11 – OAT vs EGT Limits Placard ..... 1-22

Figure 1-12 – Additional Placards ..... 1-27

Figure 1-13 – Instrument Markings (Sheet 1 of 9) ..... 1-28

Figure 1-13 – Instrument Markings (Sheet 2 of 9) ..... 1-29

Figure 1-13 – Instrument Markings (Sheet 3 of 9) ..... 1-30

Figure 1-13 – Instrument Markings (Sheet 4 of 9) ..... 1-31

Figure 1-13 – Instrument Markings (Sheet 5 of 9) ..... 1-32

Figure 1-13 – Instrument Markings (Sheet 6 of 9) ..... 1-33

Figure 1-13 – Instrument Markings (Sheet 7 of 9) ..... 1-34

Figure 1-13 – Instrument Markings (Sheet 8 of 9) ..... 1-35

Figure 1-13 – Instrument Markings (Sheet 9 of 9) ..... 1-36

• COPYRIGHT © 2007 BY EAGLE COPTERS MAINTENANCE LTD •

This document is private and confidential and is supplied on the express condition that it is not to be used for any purpose or copied or communicated to any other person without written permission from Eagle Copters Maintenance Ltd.

# Section 1

## Limitations

### 1.1 Introduction

#### Note

*Compliance with limitations in this section is required by appropriate operating rules*

Minimum and maximum limits and normal and cautionary operating ranges for helicopter and subsystems are indicated by instrument markings and placards. Instrument markings and placards represent aerodynamic calculations that are substantiated by flight test data.

Anytime an operating limit is exceeded, an appropriate entry shall be made in the helicopter logbook. The entry shall state which limit was exceeded, duration of time, extreme value attained, and any additional information essential in determining maintenance action required.

### 1.2 Basis of Certification

This helicopter is certified under FAR Part 29, Category B.

### 1.3 Types of Operation

The basic configured helicopter is approved as a ten-place helicopter with one pilot and nine passengers; or an eleven place helicopter with two pilots and nine passengers. The basic helicopter is certified for operation in day or night VFR non-icing conditions.

• COPYRIGHT © 2007 BY EAGLE COPTERS MAINTENANCE LTD •

This document is private and confidential and is supplied on the express condition that it is not to be used for any purpose or copied or communicated to any other person without written permission from Eagle Copters Maintenance Ltd.

## 1.4 Flight Crew

### Note

*Minimum cockpit (FS 47.0) weight is 170 Lbs (77.1 Kg). Refer to Section 5.*

Minimum flight crew consists of one pilot who shall operate helicopter from the right crew seat.

Left crew seat may be used for an additional pilot for VFR day and night operations when approved dual controls and copilot instrument kits are installed.

### Note

*Refer to applicable operating rules for internal cargo operations.*

## 1.5 Configuration

### 1.5.1 Required Equipment

Heated Pitot Static System  
Pilot Windshield Wiper  
Force Trim System

### 1.5.2 Optional Equipment

Refer to appropriate Flight Manual Supplement(s) for additional limitations, procedures, and performance data required for optional equipment installed.

#### 1.5.2.1 Dual Digital Clocks with USB Chargers

Devices using the Digital Clock USB chargers must use an appropriate mount that securely holds the device to the aircraft.

• COPYRIGHT © 2007 BY EAGLE COPTERS MAINTENANCE LTD •

This document is private and confidential and is supplied on the express condition that it is not to be used for any purpose or copied or communicated to any other person without written permission from Eagle Copters Maintenance Ltd.

The maximum length of the cables to be used with the USB chargers is 8 inches.



USB CABLES MUST BE ROUTED SO AS TO NOT INTERFERE WITH THE FREE MOVEMENT OF FLIGHT CONTROLS.

### 1.5.3 Doors Open/Removed

Helicopter may be flown with doors open or removed only with Bell Helicopter standard interior installed. Flight operation is approved for the following alternative configurations.

Symmetrical configurations:

Both crew doors removed

Both sliding doors locked open or removed with both hinged panels installed or removed.

Asymmetrical configurations:

Cargo doors can be opened or closed asymmetrically to a locked position with following restrictions:

1. Two-way communications between pilot and cabin crewmember.
2. All crewmembers and passengers are secured with an approved restraint.

• COPYRIGHT © 2007 BY EAGLE COPTERS MAINTENANCE LTD •

This document is private and confidential and is supplied on the express condition that it is not to be used for any purpose or copied or communicated to any other person without written permission from Eagle Copters Maintenance Ltd.

Note

*Opening or removing doors shifts the helicopter center of gravity and reduces  $V_{NE}$ . Refer to section 5 and Airspeed Limitations.*

• COPYRIGHT © 2007 BY EAGLE COPTERS MAINTENACE LTD •

This document is private and confidential and is supplied on the express condition that it is not to be used for any purpose or copied or communicated to any other person without written permission from Eagle Copters Maintenance Ltd.

TCCA Approved

Revision: **M**

Date: 2026-04-13

## 1.5.4 Passengers

### Note

Refer to section 5 for loading tables to be used in weight/CG computations.

With passenger seat kit installed per Figure 1-1, 1-2 or 1-3, the helicopter is certified for operations as a nine-passenger aircraft.

The above loading does not apply if cargo or a combination of cargo and passengers are being transported. It shall be the responsibility of the pilot to ensure that the helicopter is properly loaded so the entire flight is conducted within the limits of gross weight and center of gravity charts (Figure 1-5)

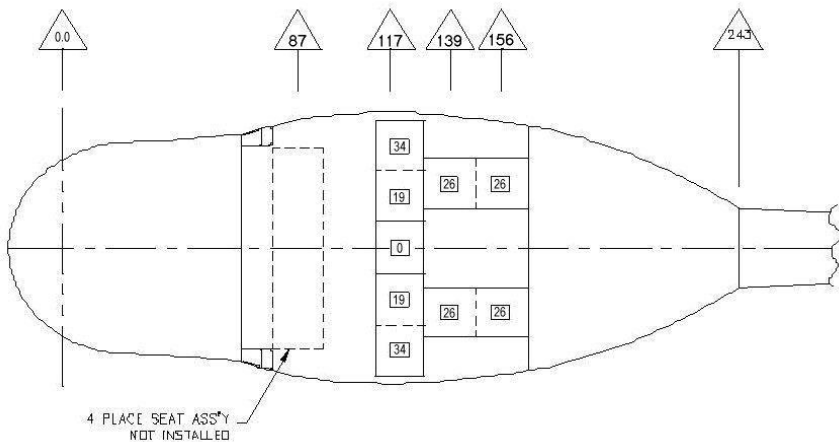

Figure 1-1 – Nine-place passenger loading configuration 1

• COPYRIGHT © 2007 BY EAGLE COPTERS MAINTENANCE LTD •

This document is private and confidential and is supplied on the express condition that it is not to be used for any purpose or copied or communicated to any other person without written permission from Eagle Copters Maintenance Ltd.

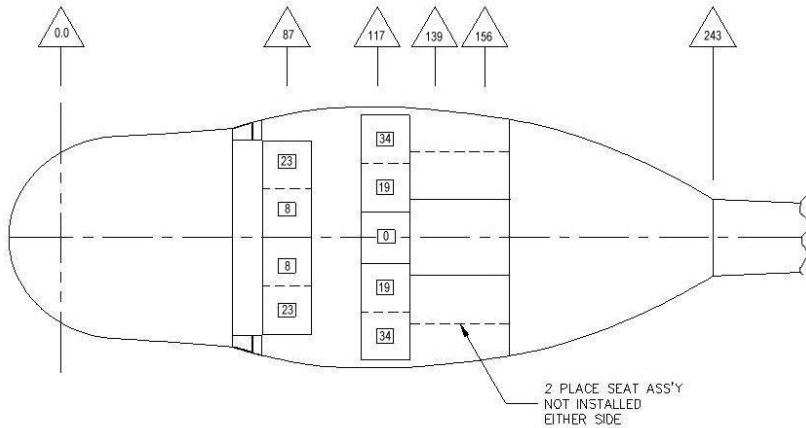

Figure 1-2 – Nine-place passenger loading configuration 2

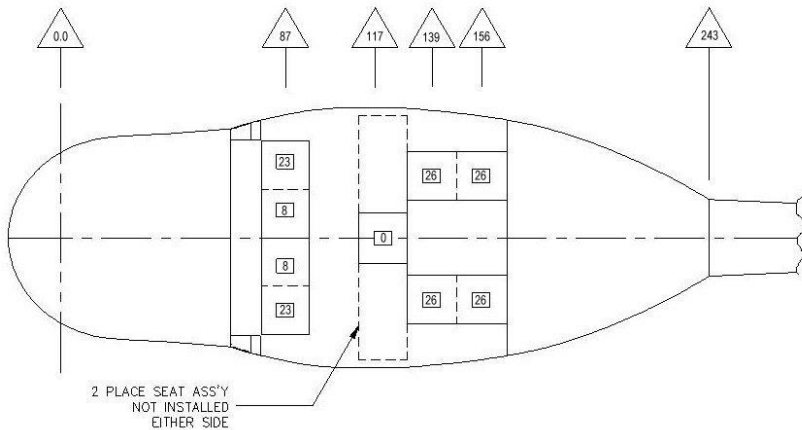

Figure 1-3 – Nine-place passenger loading configuration 3

• COPYRIGHT © 2007 BY EAGLE COPTERS MAINTENANCE LTD •

This document is private and confidential and is supplied on the express condition that it is not to be used for any purpose or copied or communicated to any other person without written permission from Eagle Copters Maintenance Ltd.

## 1.5.5 Cargo

### 1.5.5.1 Internal Cargo Configuration

Allowable deck loading for cargo is 100 pounds per square foot (4.9 kilograms/100 square centimeters). Deck mounted tiedown fittings are provided and have an airframe structural capacity of 1250 pounds (567.0 kilograms) vertical and 500 pounds (226.8 kilograms) horizontal per fitting. Provisions for installation of cargo tiedown fittings are incorporated in aft cabin bulkhead and transmission support structure and have an airframe structural capacity of 1250 pounds (567.0 kilograms) at 90 degrees to bulkhead and 500 pounds (226.8 kilograms) in any direction parallel to bulkhead. Cargo shall be secured by an approved restraint method that will not impede access to cargo in an emergency. All cargo and equipment shall be securely tied down when operating with aft cabin doors open or removed.

### 1.5.5.2 Cargo Compartment

Cargo compartment maximum allowable loading is 400 pounds (181.4 kilograms), not to exceed 100 pounds per square foot (4.9 kilograms/100 square centimeters).

• COPYRIGHT © 2007 BY EAGLE COPTERS MAINTENANCE LTD •

This document is private and confidential and is supplied on the express condition that it is not to be used for any purpose or copied or communicated to any other person without written permission from Eagle Copters Maintenance Ltd.

## 1.6 Weight and Center of Gravity

### 1.6.1 Weight

Maximum GW is 11,200 pounds (5080.3 kilograms).

Refer to weight-altitude-temperature limitations for takeoff, landing and in ground effect maneuvers chart (Figure 1-4).

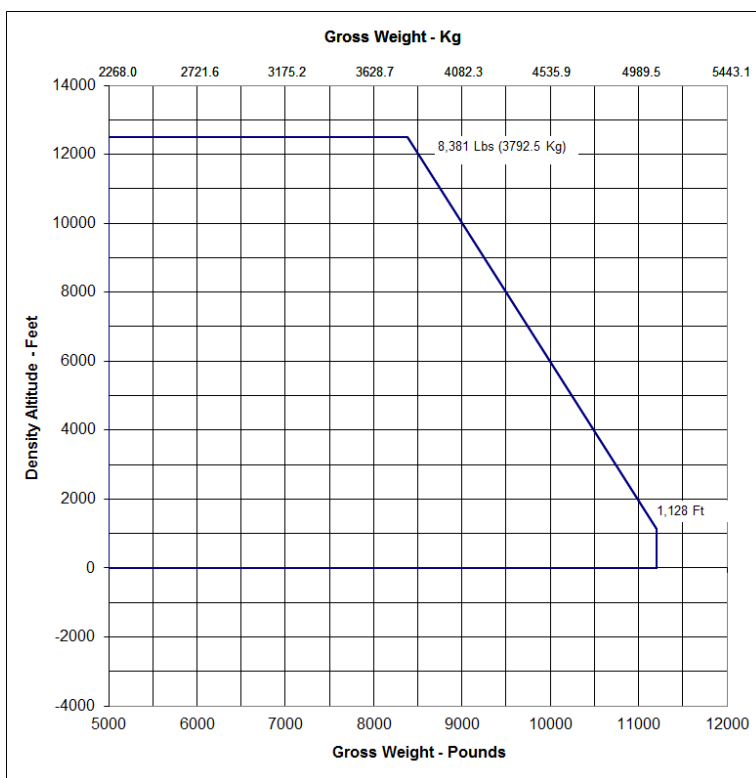

Figure 1-4 – Weight-Altitude-Temperature (WAT) Chart

• COPYRIGHT © 2007 BY EAGLE COPTERS MAINTENANCE LTD •

This document is private and confidential and is supplied on the express condition that it is not to be used for any purpose or copied or communicated to any other person without written permission from Eagle Copters Maintenance Ltd.

## 1.6.2 Center of Gravity

### 1.6.2.1 Longitudinal Center of Gravity

Longitudinal CG limits are from station 130.0 to 144.0

Longitudinal CG operational range is variable (Figure 1-5), depending upon GW, and shall be computed from weight and balance data.

#### Note

*Station 0 (datum) is located 20 inches (508 millimeters) aft of most forward point of cabin nose.*

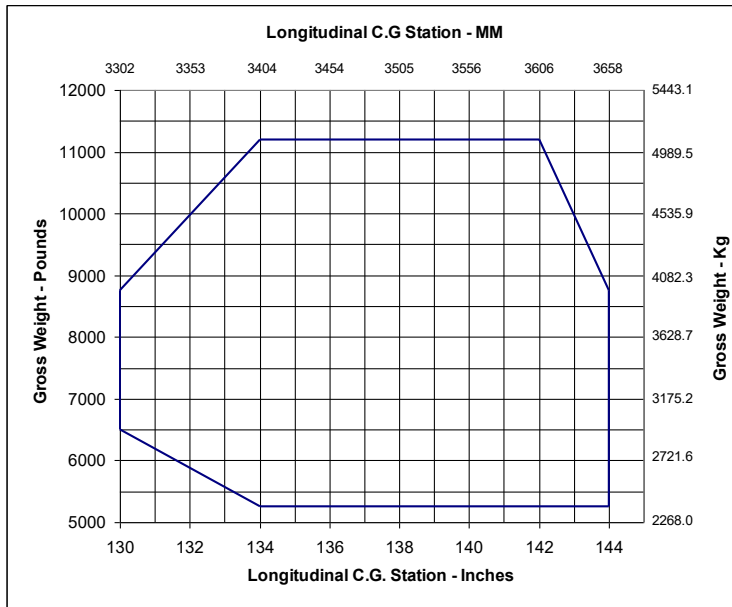

Figure 1-5 – Gross weight vs Center of Gravity Chart

• COPYRIGHT © 2007 BY EAGLE COPTERS MAINTENANCE LTD •

This document is private and confidential and is supplied on the express condition that it is not to be used for any purpose or copied or communicated to any other person without written permission from Eagle Copters Maintenance Ltd.

### 1.6.2.2 Lateral Center of Gravity

Lateral CG limits are 4.7 inches (119.4 millimeters) left and 6.5 inches (165.1 millimeters) right of fuselage centerline.

## 1.7 Airspeed

7500 pounds (3402 kilograms) GW –  $V_{NE}$  125 KIAS.

10,500 pounds (4763 kilograms) GW –  $V_{NE}$  105 KIAS.

10,500 pounds (4763 kilograms) and above GW –  $V_{NE}$  80 KIAS.

Engine torque greater than 49 PSI (88%) –  $V_{NE}$  80 KIAS.

Symmetrical doors open/off operation –  $V_{NE}$  100 KIAS unless  $V_{NE}$  Placard (Figure 1-6A) is more restrictive.

$V_{NE}$  with cargo door open/off asymmetrically is 60 KIAS.

$V_{NE}$  with cargo doors in transit or in an unlocked position is 60 KIAS.

$V_{NE}$  decreases linearly from 125 knots to 105 knots (Refer to Placards and Decals, Figure 1-6A).

$V_{NE}$  decreases 3 knots per 1000 feet above 3000 feet Hd.

Maximum allowable tailwind is 20 knots when operating above 10,500 Lbs.

Maximum allowable tailwind is 30 knots when operating below 10,500 Lbs.

Maximum allowable crosswind is 30 knots.

• COPYRIGHT © 2007 BY EAGLE COPTERS MAINTENANCE LTD •

This document is private and confidential and is supplied on the express condition that it is not to be used for any purpose or copied or communicated to any other person without written permission from Eagle Copters Maintenance Ltd.

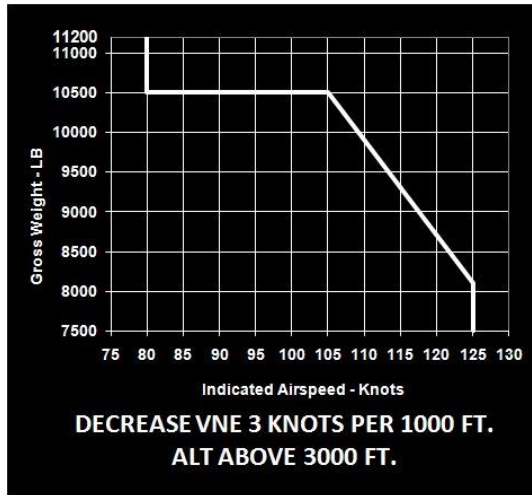

Figure 1-6A – V<sub>NE</sub> Placard



Figure 1-6B – Fuel Capacity Placard

• COPYRIGHT © 2007 BY EAGLE COPTERS MAINTENANCE LTD •

This document is private and confidential and is supplied on the express condition that it is not to be used for any purpose or copied or communicated to any other person without written permission from Eagle Copters Maintenance Ltd.

## **1.8 Altitude**

Maximum operating – 20,000 H<sub>P</sub>.

Refer to applicable operating rules for high altitude oxygen requirements.

Restart in flight is not recommended unless above 3000 ft AGL.

## **1.9 Maneuvering**

### **1.9.1 Prohibited Maneuvers**

Aerobatic maneuvers are prohibited.

### **1.9.2 Climb and Descent**

Maximum allowable rate of climb is 2,000 feet per minute

### **1.9.3 Slope Landings**

Slope landings are limited to side slopes no greater than 10 degrees

• COPYRIGHT © 2007 BY EAGLE COPTERS MAINTENANCE LTD •

This document is private and confidential and is supplied on the express condition that it is not to be used for any purpose or copied or communicated to any other person without written permission from Eagle Copters Maintenance Ltd.

## 1.10 Power Limits for Take Off

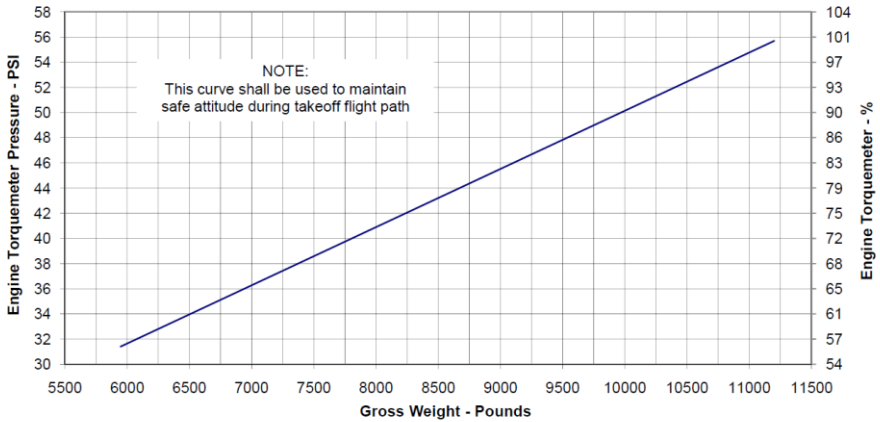

Figure 1-8 – Power Limits for Takeoff

### Note

*The POWER LIMITS FOR TAKEOFF Chart is based on power required to hover in-ground-effect plus an additional increment of power. The limitations are imposed to preclude the possibility of unsafe nose down attitude during the takeoff flight path. These limits shall be observed until 65 knots and at least 35 feet above the ground are obtained, after which ENGINE POWER LIMITATIONS FOR FLIGHT may be used.*

• COPYRIGHT © 2007 BY EAGLE COPTERS MAINTENANCE LTD •

This document is private and confidential and is supplied on the express condition that it is not to be used for any purpose or copied or communicated to any other person without written permission from Eagle Copters Maintenance Ltd.

This Page Intentionally left blank

Figure 1-7 Height Velocity Chart is

Now Figure 4-14 (See Section 4.8 in Performance)

• COPYRIGHT © 2007 BY EAGLE COPTERS MAINTENACE LTD •

This document is private and confidential and is supplied on the express condition that it is not to be used for any purpose or copied or communicated to any other person without written permission from Eagle Copters Maintenance Ltd.

TCCA Approved

Revision: **M**

Date: 2026-04-13

## 1.11 Ambient Temperature

Maximum sea level ambient air temperature for operation is +49°C (+120°F) decreases with altitude at standard lapse rate (2°C per 1000 feet H<sub>P</sub>). For S/N 30687, 30817 and 30599 (G1), minimum ambient air temperature at all altitudes is -54°C (-65°F). For all other S/N (G2) minimum ambient air temperature at all altitudes is -30°C (-26°F). Refer to Weight-altitude-temperature limitations for takeoff, landing and in ground effect maneuvers chart (Figure 1-4). G1 is generation 1 aircraft with AC instruments. G2 is generation 2 aircraft with DC instruments.

Engine de-icing shall be turned ON for flight in visible moisture at temperatures below +4.4°C (+40°F).

The maximum ambient temperature for use of engine de-icing is +4.4°C (+40°F).

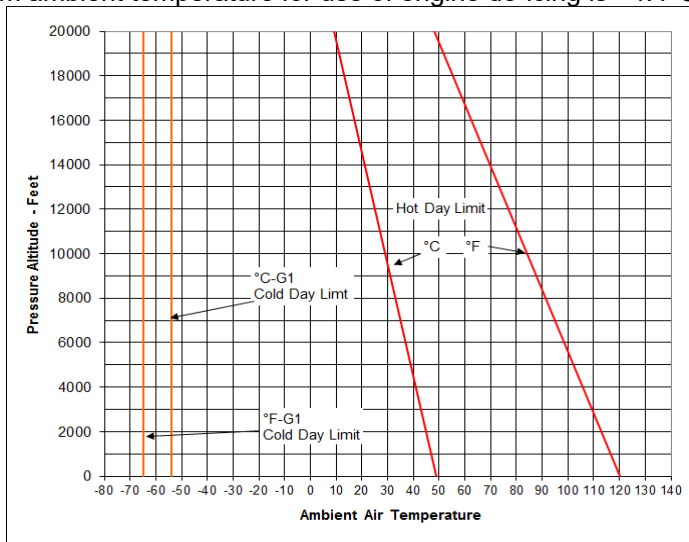

Figure 1-9A – Pressure Altitude vs Ambient Air Temperature Chart  
(For S/N 30687, 30817, 30599)

• COPYRIGHT © 2007 BY EAGLE COPTERS MAINTENANCE LTD •

This document is private and confidential and is supplied on the express condition that it is not to be used for any purpose or copied or communicated to any other person without written permission from Eagle Copters Maintenance Ltd.

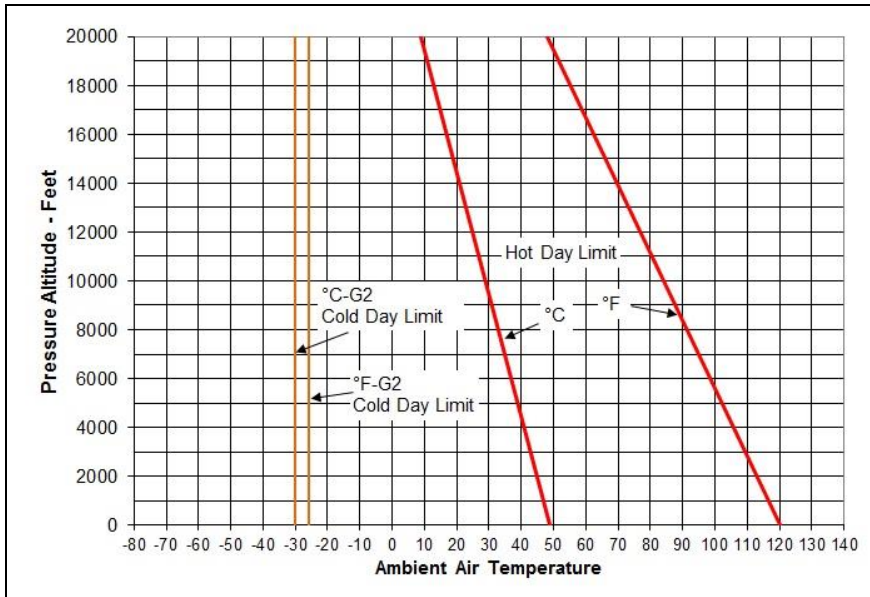

Figure 1-9B – Pressure vs Ambient Air Temperature Chart  
(For all other S/N).

## 1.12 Electrical

### 1.12.1 Battery

The aircraft must be equipped with a 24 volt, 42 amp-hour, lead-acid battery.

### 1.12.2 Ground Power Unit

28 VDC ground power units for starting shall be rated at a minimum of 500 amps and a maximum of 1000 amps.

### 1.12.3 Starter

Three energized periods allowed per hour.

• COPYRIGHT © 2007 BY EAGLE COPTERS MAINTENANCE LTD •

This document is private and confidential and is supplied on the express condition that it is not to be used for any purpose or copied or communicated to any other person without written permission from Eagle Copters Maintenance Ltd.

Revision: **M**

Date: 2026-04-13

TCCA Approved

Limit starter energizing time to:  
35 seconds – ON

3 minutes – OFF

35 seconds – ON

30 minutes – OFF

35 seconds – ON

30 minutes – OFF

### 1.12.4 Loadmeter

Maximum – 0.50 (150 AMP) red radial

#### Note

*Generator loading above 0.50 (150A) prohibited in flight.  
Momentary loads above 0.50 (150A) are allowed for battery  
recharging during ground run only.*

## 1.13 Power Plant

Honeywell T5317 A/B/BCV

### 1.13.1 Gas Producer (N<sub>1</sub>) RPM

Maximum continuous 101%

Takeoff power (5 minutes) 101% to 105%

Maximum 105%

• COPYRIGHT © 2007 BY EAGLE COPTERS MAINTENANCE LTD •

This document is private and confidential and is supplied on the express condition that it is not to be used for any purpose or copied or communicated to any other person without written permission from Eagle Copters Maintenance Ltd.

### 1.13.2 Power Turbine (N<sub>2</sub>) RPM

|                    |                 |
|--------------------|-----------------|
| Minimum continuous | 97% rpm         |
| Continuous         | 97% to 100% rpm |
| Maximum            | 100% rpm        |

### 1.13.3 Torquemeter Pressure (%)

|                           |                                |
|---------------------------|--------------------------------|
| Continuous operation      | 12 to 49.0 PSI (0% to 88%)     |
| Takeoff power (5 minutes) | 49.0 to 55.7 PSI (88% to 100%) |
| Maximum                   | 55.7 PSI (100%)                |

Note  
( ) corresponds to DC powered system

### 1.13.4 Exhaust Gas Temperature vs OAT Limitations (T5317A Only)

Note:

*EGT of 680°C should not be exceeded during the starting and acceleration cycle. Consult Engine Manual, Operation and Maintenance Instructions, if 680°C temperature is exceeded.*

Allowable EGT limits vary with outside air temperature. The variable EGT limits are shown on the OAT vs EGT Limits placard (see Figure 1-11). This placard indicates EGT limits for maximum continuous power and take off power. The EGT limits applicable are to be determined by reading the OAT gauge and referring to the EGT limits indicated on the OAT vs EGT Limits placard for the outside air temperature indicated. This placard does not supersede the ambient air temperature limitations in section 1.11.

• COPYRIGHT © 2007 BY EAGLE COPTERS MAINTENANCE LTD •

This document is private and confidential and is supplied on the express condition that it is not to be used for any purpose or copied or communicated to any other person without written permission from Eagle Copters Maintenance Ltd.

**THE FOLLOWING EGT LIMITS ARE APPLICABLE AND SUPERSEDE THE EGT LIMITS INDICATED ON THE BELL EGT. VS. OAT. GAUGE WHEN THE T5317A ENGINE IS INSTALLED**

**EGT VS OAT LIMITS (°C)**

| OAT       | -54        | -50        | -40        | -30        | -20        | -10        | 0          | 10         | 20         | 30         | 40         | 50         | 52         |
|-----------|------------|------------|------------|------------|------------|------------|------------|------------|------------|------------|------------|------------|------------|
| T.O./M.C. | 618<br>589 | 618<br>591 | 622<br>594 | 628<br>598 | 630<br>602 | 635<br>607 | 640<br>614 | 646<br>622 | 652<br>631 | 659<br>641 | 668<br>651 | 678<br>663 | 680<br>665 |

D212-725-6-005

Figure 1-11 – OAT vs EGT Limits Placard  
(P/N D212-725-6-005)

### 1.13.5 Measured Gas Temp (T5317B/BCV Only)

#### 1.13.5.1 Normal Operation:

Continuous 400 to 820°C

Maximum continuous 820°C

Takeoff (5 minutes) 820 to 863°

Maximum takeoff 863°C

#### 1.13.5.2 Starting Limits

Normal 400 to 863°C

5 second limit 863 to 926°C

Maximum 926°C

### 1.13.6 Fuel Pressure

Minimum 4 PSI

Continuous 4 – 35 PSI

Maximum 35 PSI

• COPYRIGHT © 2007 BY EAGLE COPTERS MAINTENANCE LTD •

This document is private and confidential and is supplied on the express condition that it is not to be used for any purpose or copied or communicated to any other person without written permission from Eagle Copters Maintenance Ltd.

### **1.13.7 Oil Pressure – Engine**

|            |               |
|------------|---------------|
| Minimum    | 25 to 80 PSI  |
| Continuous | 80 to 100 PSI |
| Maximum    | 100 PSI       |

### **1.13.8 Oil Temperature – Engine**

|         |      |
|---------|------|
| Maximum | 93°C |
|---------|------|

## **1.14 Transmission**

### **1.14.1 Transmission Oil Pressure**

|                      |              |
|----------------------|--------------|
| Minimum for idle     | 30 PSI       |
| Idle range           | 30 to 40 PSI |
| Continuous operation | 40 to 70 PSI |
| Maximum              | 70 PSI       |

### **1.14.2 Transmission Oil Temperature**

|                      |             |
|----------------------|-------------|
| Continuous operation | 15 to 110°C |
| Maximum              | 110°C       |

• COPYRIGHT © 2007 BY EAGLE COPTERS MAINTENANCE LTD •

This document is private and confidential and is supplied on the express condition that it is not to be used for any purpose or copied or communicated to any other person without written permission from Eagle Copters Maintenance Ltd.

## 1.15 Rotor

### 1.15.1 Rotor RPM (N<sub>R</sub>) – Power On

|            |            |
|------------|------------|
| Minimum    | 97%        |
| Continuous | 97 to 100% |
| Maximum    | 100%       |

### 1.15.2 Rotor RPM (N<sub>R</sub>) – Power Off

|         |        |
|---------|--------|
| Minimum | 91%    |
| Maximum | 104.5% |

## 1.16 Hydraulic

Both hydraulic systems shall be operative prior to takeoff.

### 1.16.1 Hydraulic Oil

Hydraulic fluid type MIL-H-5606 (NATO H-515) shall be used at all ambient temperatures.

### 1.16.2 Hydraulic Pressure

|                  |                 |
|------------------|-----------------|
| Minimum          | 600 PSI         |
| Caution range    | 600 to 900 PSI  |
| Normal operating | 900 to 1100 PSI |
| Maximum          | 1100 PSI        |

• COPYRIGHT © 2007 BY EAGLE COPTERS MAINTENANCE LTD •

This document is private and confidential and is supplied on the express condition that it is not to be used for any purpose or copied or communicated to any other person without written permission from Eagle Copters Maintenance Ltd.

### 1.16.3 Hydraulic Temperature

Maximum 88°C

## 1.17 Fuel and Oil

For further information on all fluids see section 2 of the Manufacturer's Data.

### 1.17.1 Fuel

Turbine fuel ASTM 1655, Type B, or MIL-T-5624, Grade JP-4, may be used at all ambient temperatures

Turbine fuel ASTM 1655, Type A or A-1, MIL-T-5624, Grade JP-5, or MIL-T-83133, Grade JP-8, limited to ambient temperatures -29°C (-20°F) and above. Maximum viscosity for T5317A is 12 centistokes. Maximum viscosity for T5317B is 6 centistokes.

#### Note

*Engine start may not be successful at ambient temperatures below -12.2°C (+10°F) or altitudes above 8000 feet pressure altitude using fuel conforming to ASTM 1655, Type A or A-1 (JP-5 or JP-8).*

### 1.17.2 Anti-Icing Additive

When operating in temperatures below +40°F (+4°C), all fuel used in this helicopter shall contain an anti-icing additive meeting the specification requirements of PFA-55MB. Concentration of this additive in fuel in a loaded fuel tank shall not be less than 0.035% nor more than 0.15% by volume. The minimum concentration of the additive in the fuel with which the helicopter is to be refueled should be at least 0.06% by volume to assure a loaded fuel tank concentration of at least 0.035%

• COPYRIGHT © 2007 BY EAGLE COPTERS MAINTENANCE LTD •

This document is private and confidential and is supplied on the express condition that it is not to be used for any purpose or copied or communicated to any other person without written permission from Eagle Copters Maintenance Ltd.

### 1.17.3 Oil – Engine

Oil conforming to MIL-L-7808E (and subsequent) may be used at all ambient temperatures.

Oil conforming to MIL-L-23699 may be used at all ambient temperatures above -40°C (-40°F) engine only

### 1.17.4 Oil – Transmission, Intermediate and Tail Rotor Gearboxes

Oil conforming to MIL-L-7808 (NATO 0-148) may be used at all ambient temperatures.

Oil conforming to DOD-L-85734AS (Turbine 555) and MIL-L-23699 (NATO 0-156) may be used at all ambient air temperatures above -40°C (-40°F).

#### Note

*DOD-L-85734S or MIL-L-23699 is recommended.*

## 1.18 Rotor Brake

Engine starts with rotor brake engaged are prohibited. Rotor brake application is limited to ground operations and shall not be applied until the engine has been shut down and ROTOR RPM has decreased to 40% or less.

## 1.19 Heater

Heater shall not be operated when OAT is above 21°C (69.8°F)

• COPYRIGHT © 2007 BY EAGLE COPTERS MAINTENANCE LTD •

This document is private and confidential and is supplied on the express condition that it is not to be used for any purpose or copied or communicated to any other person without written permission from Eagle Copters Maintenance Ltd.

## 1.20 Additional Placards

Refer to Figure 1-12 for Placards and Decals.

**THIS AIRCRAFT IS EQUIPPED WITH A SINGLE T5317A/B ENGINE AND APPROVED FOR DAY/NIGHT VFR OPERATIONS ONLY (NO IFR, NO ICING) WITH 9 PASSENGERS OR LESS. SEE DART AEROSPACE FLIGHT MANUAL SUPPLEMENT FMS-D212-725-1 FOR MODIFIED OPERATING LIMITATIONS, PROCEDURES, PERFORMANCE DATA, AND APPROVED SEATING CONFIGURATIONS.**

D212-725-6-001

### Limitations Placard (P/N D212-725-6-001)

**MAXIMUM GAS PRODUCER SPEED**

TAKEOFF POWER = 105.0%  
MAX. CONT. POWER = 101.0%

D212-725-6-003

### Gas Producer (N<sub>1</sub>) Speed Placard (P/N D212-725-6-003)

**DO NOT OPERATE  
HEATER ABOVE  
21 °C O.A.T.**

**MAX CABLE LENGTH  
8 INCH**

**CARGO FIRE  
TEST SWITCH**

Typical



Panel aft end of overhead console  
Figure 1-12 – Additional Placards

• COPYRIGHT © 2007 BY EAGLE COPTERS MAINTENANCE LTD •

This document is private and confidential and is supplied on the express condition that it is not to be used for any purpose or copied or communicated to any other person without written permission from Eagle Copters Maintenance Ltd.



## 1.21 Instrument Markings

Refer to Figure 1-13 for instrument range markings.

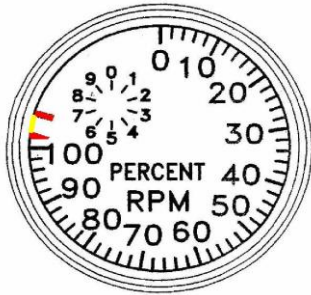
Gas Producer Tachometer (for aircraft with AC powered instrument system)





Gas Producer Tachometer

-  101% Maximum Continuous
-  101 to 105%
-  105% Maximum Takeoff Power

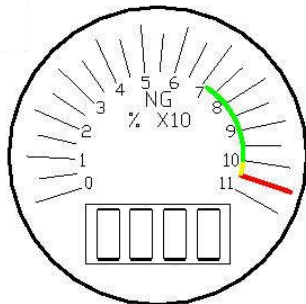
Gas Producer Tachometer (for aircraft with DC powered instrument system)



Gas Producer Tachometer

-  72 to 101% Maximum Continuous
-  101 to 105%
-  105% Maximum Takeoff Power

Note: Engine  $N_g$  idle speeds as low as 70% are normal

Figure 1-13 – Instrument Markings (Sheet 1 of 9)

• COPYRIGHT © 2007 BY EAGLE COPTERS MAINTENANCE LTD •

This document is private and confidential and is supplied on the express condition that it is not to be used for any purpose or copied or communicated to any other person without written permission from Eagle Copters Maintenance Ltd.

Exhaust Gas Temperature (EGT) (T53-17A Engine)

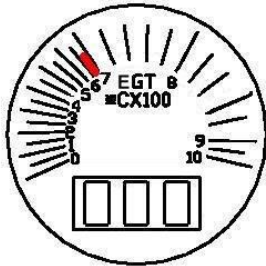

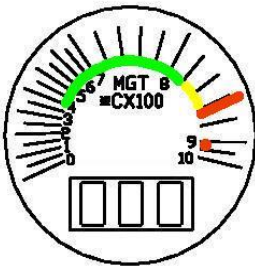

 Maximum 680°C

Measured Gas Temperature (MGT) (T53-17B/BCV Engine)



Normal Operations

-  400 to 820°C Max Continuous
-  820 to 863°C Takeoff (5 minutes)
-  863°C Maximum (Takeoff)

Starting Limits

- 400 to 863°C Normal
- 863 to 926°C Caution (5 seconds)
- 926°C Maximum

Figure 1-13 – Instrument Markings (Sheet 2 of 9)



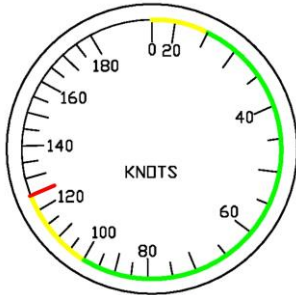

• COPYRIGHT © 2007 BY EAGLE COPTERS MAINTENANCE LTD •

This document is private and confidential and is supplied on the express condition that it is not to be used for any purpose or copied or communicated to any other person without written permission from Eagle Copters Maintenance Ltd.

### Airspeed Indicator



#### Airspeed

|   |                  |
|---|------------------|
|  | 0 to 25 knots    |
|  | 25 to 100 knots  |
|  | 100 to 125 knots |
|  | 125 knots        |

### Fuel Pressure

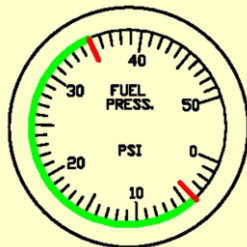

#### Fuel Pressure

|   |             |
|---|-------------|
|  | 4 PSI       |
|  | 4 to 35 PSI |
|  | 35 PSI      |

Figure 1-13 – Instrument Markings (Sheet 3 of 9)

• COPYRIGHT © 2007 BY EAGLE COPTERS MAINTENANCE LTD •

This document is private and confidential and is supplied on the express condition that it is not to be used for any purpose or copied or communicated to any other person without written permission from Eagle Copters Maintenance Ltd.

Engine Oil Temperature and Pressure (for aircraft with AC powered instrument system)

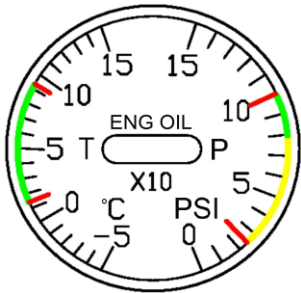

Engine Oil Temperature

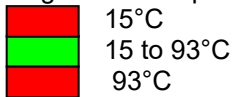

Engine Oil Pressure

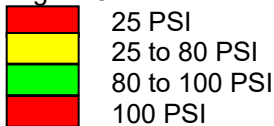

Engine Oil Temperature and Pressure (for aircraft with DC powered instrument system)

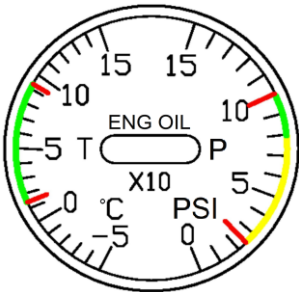

Engine Oil Temperature

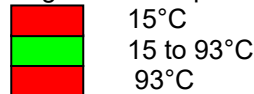

Engine Oil Pressure

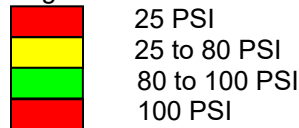
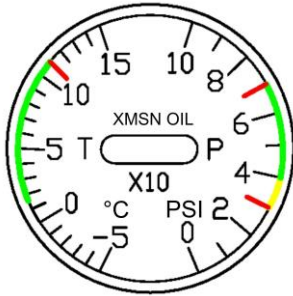

Figure 1-13 – Instrument Markings (Sheet 4 of 9)

• COPYRIGHT © 2007 BY EAGLE COPTERS MAINTENANCE LTD •

This document is private and confidential and is supplied on the express condition that it is not to be used for any purpose or copied or communicated to any other person without written permission from Eagle Copters Maintenance Ltd.

### Transmission Oil Temperature and Pressure



#### Transmission Oil Temperature

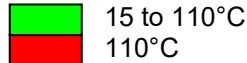

#### Transmission Oil Pressure

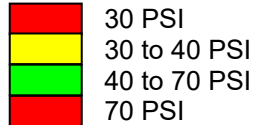

### Hydraulic Fluid Temperature and Pressure Indicator

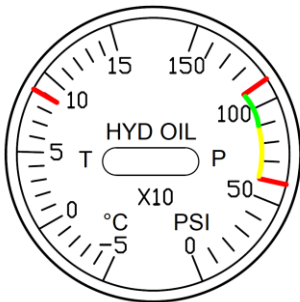

#### Hydraulic Fluid Temperature



#### Hydraulic Fluid Pressure

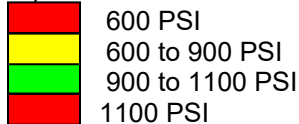
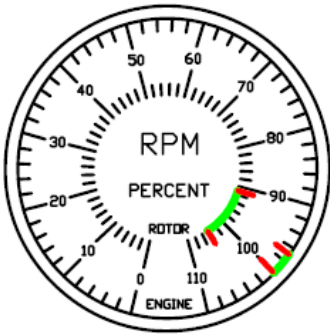

Figure 1-13 – Instrument Markings (Sheet 5 of 9)

• COPYRIGHT © 2007 BY EAGLE COPTERS MAINTENANCE LTD •

This document is private and confidential and is supplied on the express condition that it is not to be used for any purpose or copied or communicated to any other person without written permission from Eagle Copters Maintenance Ltd.

Dual Tachometer (for aircraft with AC powered instrument system)



Engine Tachometer

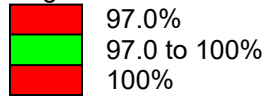

Rotor Tachometer

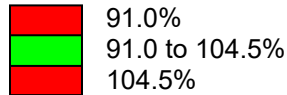

Dual Tachometer (for aircraft with DC powered instrument system)

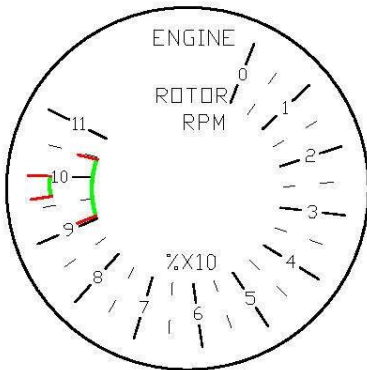

Engine Tachometer

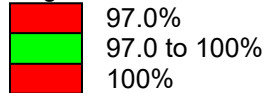

Rotor Tachometer

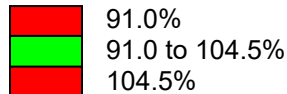
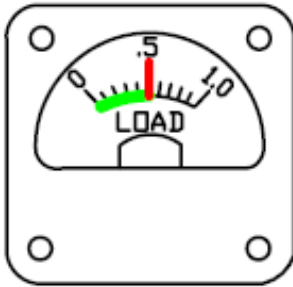



Figure 1-13 – Instrument Markings (Sheet 6 of 9)

• COPYRIGHT © 2007 BY EAGLE COPTERS MAINTENANCE LTD •

This document is private and confidential and is supplied on the express condition that it is not to be used for any purpose or copied or communicated to any other person without written permission from Eagle Copters Maintenance Ltd.

Generator Loadmeter (for aircraft with AC powered instrument system)



Generator Loadmeter  
 0.0 to 0.5 – Continuous  
 0.5 – Maximum

Voltmeter (for aircraft with DC powered instrument system)

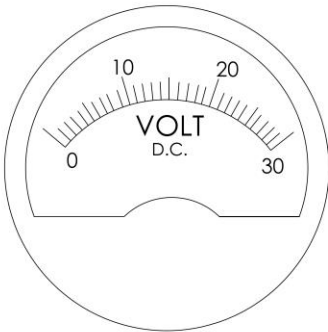
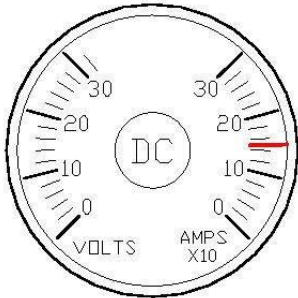

Figure 1-13 – Instrument Markings (Sheet 7 of 9)

• COPYRIGHT © 2007 BY EAGLE COPTERS MAINTENANCE LTD •

This document is private and confidential and is supplied on the express condition that it is not to be used for any purpose or copied or communicated to any other person without written permission from Eagle Copters Maintenance Ltd.

Volt/Ammeter (for aircraft with DC powered instrument system)





Volt/Ammeter

 150 – Maximum

Torquemeter (for aircraft with AC powered instrument system)



Torquemeter

 12.0 to 49.0 PSI  
 49.0 to 55.7 PSI  
 55.7 PSI

Note: 49.0 PSI may be exceeded provided airspeed is below 80 knots

Figure 1-13 – Instrument Markings (Sheet 8 of 9)

• COPYRIGHT © 2007 BY EAGLE COPTERS MAINTENANCE LTD •

This document is private and confidential and is supplied on the express condition that it is not to be used for any purpose or copied or communicated to any other person without written permission from Eagle Copters Maintenance Ltd.

Torquemeter (for aircraft with DC powered instrument system)

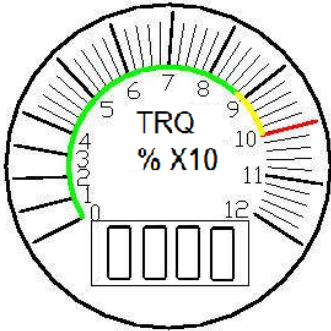

Torquemeter

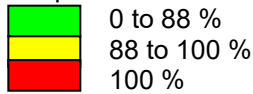

Note: 88 % may be exceeded  
provided airspeed is below 80 knots

Figure 1-13 – Instrument Markings (Sheet 9 of 9)

• COPYRIGHT © 2007 BY EAGLE COPTERS MAINTENACE LTD •

This document is private and confidential and is supplied on the express condition that it is not to be used for any purpose or copied or communicated to any other person without written permission from Eagle Copters Maintenance Ltd.

TCCA Approved

Revision: **M**

Date: 2026-04-13

## Section 2

### *Normal Procedures*

#### Table of Contents

|       |   |      |
|-------|---|------|
| 2.1   | Introduction.....                                 | 2-3  |
| 2.2   | Flight Planning.....                              | 2-3  |
| 2.2.1 | Takeoff and Landing.....                          | 2-4  |
| 2.2.2 | Weight and Balance .....                          | 2-4  |
| 2.3   | Preflight Check.....                              | 2-4  |
| 2.3.1 | Before Exterior Check .....                       | 2-5  |
| 2.3.2 | Exterior Check.....                               | 2-7  |
| 2.4   | Interior and Pre-start Check .....                | 2-12 |
| 2.4.1 | Pre-start Check .....                             | 2-13 |
| 2.5   | Engine Start.....                                 | 2-19 |
| 2.5.1 | Engine Start – Battery or Ground Power Unit ..... | 2-19 |
| 2.5.2 | Engine Fails to Start.....                        | 2-21 |
| 2.6   | Systems Check .....                               | 2-21 |
| 2.6.1 | Force Trim Check.....                             | 2-21 |
| 2.6.2 | Preliminary Hydraulic Check .....                 | 2-22 |
| 2.6.3 | Engine Fuel Control.....                          | 2-22 |
| 2.6.4 | Rpm Control .....                                 | 2-23 |
| 2.6.5 | Anti-ice Check .....                              | 2-23 |
| 2.6.6 | Electrical System Checks.....                     | 2-23 |
| 2.6.7 | Hydraulic System Checks .....                     | 2-24 |
| 2.6.8 | Cabin Heater Check.....                           | 2-27 |
| 2.7   | Before Takeoff.....                               | 2-27 |
| 2.8   | Takeoff .....                                     | 2-28 |
| 2.9   | In-Flight Operation.....                          | 2-29 |
| 2.10  | Descent and Landing .....                         | 2-29 |
| 2.11  | After Landing .....                               | 2-30 |
| 2.12  | Engine Shutdown .....                             | 2-30 |
| 2.13  | Post Flight Check .....                           | 2-32 |

• COPYRIGHT © 2007 BY EAGLE COPTERS MAINTENANCE LTD •

This document is private and confidential and is supplied on the express condition that it is not to be used for any purpose or copied or communicated to any other person without written permission from Eagle Copters Maintenance Ltd.



## List of Figures

Figure 2-1 – Preflight Check Sequence. .... 2-6

• COPYRIGHT © 2007 BY EAGLE COPTERS MAINTENANCE LTD •

This document is private and confidential and is supplied on the express condition that it is not to be used for any purpose or copied or communicated to any other person without written permission from Eagle Copters Maintenance Ltd.

TCCA Approved

Revision: **M**  
Date: 2026-04-13

## Section 2

### *Normal Procedures*

#### **2.1 Introduction**

This section contains instructions and procedures for operating the helicopter from planning stage, through actual flight conditions, to securing helicopter after landing.

Normal and standard conditions are assumed in these procedures. Pertinent data in other sections is referenced when applicable.

Instructions and procedures contained herein are written for purpose of standardization and are not applicable to all situations.

Anytime an operating limitation is exceeded, an appropriate entry shall be made in the helicopter logbook. The entry shall state which limit was exceeded, the duration of time, the extreme value attained, and any additional information essential in determining the maintenance action required.

#### **2.2 Flight Planning**

Planning of mission to be accomplished will provide pilot with data to be used during flight. Information to be used can be compiled as follows:

- Check type of mission to be performed and destination.
- Select appropriate performance charts to be used from Section 4.

• COPYRIGHT © 2007 BY EAGLE COPTERS MAINTENANCE LTD •

This document is private and confidential and is supplied on the express condition that it is not to be used for any purpose or copied or communicated to any other person without written permission from Eagle Copters Maintenance Ltd.

## 2.2.1 Takeoff and Landing

Refer to Section 1 for takeoff and landing weight limits and to Section 4 for takeoff and landing data.

## 2.2.2 Weight and Balance

Determine proper weight and balance of helicopter as follows:

- Consult applicable weight and balance instructions provided in Section 5.
- Determine weight of fuel, oil, load etc., compute takeoff and anticipated landing GW, and check helicopter CG locations.
- Ensure weight and balance limitations in Section 1 are not exceeded.

## 2.3 Preflight Check

Pilot is responsible for determining whether helicopter is in condition for safe flight. Refer to Figure 2-1 for preflight check sequence.

### Note

*Preflight check is not intended to be a detailed mechanical inspection but a guide to check condition of helicopter. This check may be made as comprehensive as conditions warrant.*

*All areas checked shall include a visual check for evidence of corrosion, particularly when helicopter is flown near or over salt water or in areas of high industrial emissions.*

• COPYRIGHT © 2007 BY EAGLE COPTERS MAINTENANCE LTD •

This document is private and confidential and is supplied on the express condition that it is not to be used for any purpose or copied or communicated to any other person without written permission from Eagle Copters Maintenance Ltd.

### 2.3.1 Before Exterior Check

Flight planning – Completed.

Publications – Check.

Ensure helicopter has been serviced as required.

Gross weight and CG – Computed.

Main and tail rotor blades – Remove tie downs, check condition of blades and rotate in normal 90° to fuselage position. Stow tie downs.

Pitot tube cover(s) – Remove and stow.

Engine air intake covers – Remove and stow.

Aft fuel sumps – Drain samples as follows:

LH and RH BOOST PUMP switches – OFF.

FUEL VALVE switch – OFF.

Fuel sump drain buttons (left and right) – Press.

BATTERY Switch – OFF.

Fuel Filter – Drain before first flight of day as follows:

LH and RH BOOST PUMP switches – ON.

FUEL VALVE switch – ON.

BATTERY Switch – ON.

Fuel filter – Drain sample.

• COPYRIGHT © 2007 BY EAGLE COPTERS MAINTENANCE LTD •

This document is private and confidential and is supplied on the express condition that it is not to be used for any purpose or copied or communicated to any other person without written permission from Eagle Copters Maintenance Ltd.

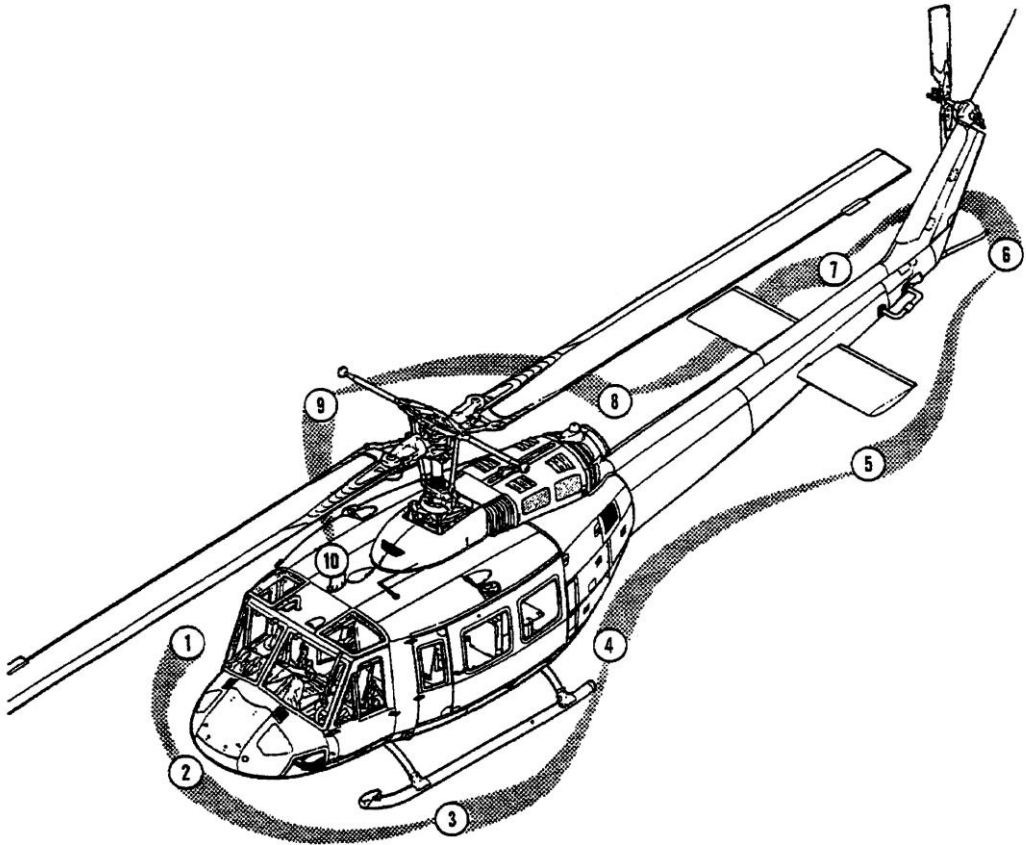

Figure 2-1 – Preflight Check Sequence.

• COPYRIGHT © 2007 BY EAGLE COPTERS MAINTENANCE LTD •

This document is private and confidential and is supplied on the express condition that it is not to be used for any purpose or copied or communicated to any other person without written permission from Eagle Copters Maintenance Ltd.

## 2.3.2 Exterior Check

**Warning**

**IF HELICOPTER HAS BEEN EXPOSED TO SNOW OR ICING CONDITIONS, SNOW AND ICE SHALL BE REMOVED PRIOR TO FLIGHT.**

### 1. AREA 1 – FRONT FUSELAGE

Pilot door – Condition and operation; windows clean. Check security of emergency release handles.

Portable fire extinguishers – Check for charge, seal not broken and security.

Rotor blade – Condition and cleanliness.

Right static port – Unobstructed

### 2. AREA 2 – CABIN NOSE

Upper Cabin area – Condition of vents, windshields, wipers, OAT probe.

Pitot tube(s) – Unobstructed.

Cabin nose ventilators – Unobstructed.

Nose compartment door – Secured

Pilot chin window – Check hydraulic clog indicator green, or for alternate indicator, all black.

Transmission chip detector indicators (if installed) – Check

Battery vent and drain lines – Unobstructed.

• COPYRIGHT © 2007 BY EAGLE COPTERS MAINTENANCE LTD •

This document is private and confidential and is supplied on the express condition that it is not to be used for any purpose or copied or communicated to any other person without written permission from Eagle Copters Maintenance Ltd.

Searchlight and landing light – Stowed

Antennas – Condition and security.

Cargo mirror (if installed) – Secure and clean.

Copilot chin window – Check for FOD and clean.

Left static port – Unobstructed.

### **3. AREA 3 – FUSELAGE LEFT SIDE**

Copilot door – Condition and operation; windows clean. Check security of emergency release handles.

Fuselage – Check condition of skin.

Position lights – Security and condition.

Passenger door – Check condition and operation; glass clean. Condition of pop-out windows.

Left hydraulic reservoir – Visually check fluid level

Engine compartment – Check fuel and oil lines and connections for condition, security and leaks.

Engine components – General condition.

Access doors and engine cowling – Secured.

### **4. AREA 4 – FUSELAGE – AFT LEFT SIDE**

Avionics compartment – Security of components.

• COPYRIGHT © 2007 BY EAGLE COPTERS MAINTENANCE LTD •

This document is private and confidential and is supplied on the express condition that it is not to be used for any purpose or copied or communicated to any other person without written permission from Eagle Copters Maintenance Ltd.

2<sup>nd</sup> tail rotor driveshaft compartment – Check.  
Fire extinguisher bottle – Check for proper pressure.  
Engine exhaust – Cover removed; unobstructed  
All access doors – Secured  
Fuselage – Condition.  
Drain lines – Clean, unobstructed.  
Oil cooler blower exhaust – Unobstructed.

**5. AREA 5 – TAILBOOM LEFT SIDE**

Tail rotor driveshaft covers – Secured.  
Tailboom – Condition  
Elevator – Condition and security



DO NOT BEND ELEVATOR TRAILING EDGE TAB.

Main rotor blade – Verify tie down removed.

**6. AREA 6 – TAILBOOM AFT**

Antennas – Condition and security (if installed)  
Tail rotor blades – Visually check condition and cleanliness.

• COPYRIGHT © 2007 BY EAGLE COPTERS MAINTENANCE LTD •

This document is private and confidential and is supplied on the express condition that it is not to be used for any purpose or copied or communicated to any other person without written permission from Eagle Copters Maintenance Ltd.



DO NOT ROTATE TAIL ROTOR BY HAND USING TAIL ROTOR BLADES.

Tail rotor – Condition and free movement on flapping axis.

Tail rotor (90°) gearbox – Verify presence of oil in sight gauge. Visually check oil level, check filler cap and chip detector plug for security.

Vertical fin – Condition

Position lights – Condition and security.

Tail skid – Condition and security.

Intermediate (42°) gearbox – Verify presence of oil in sight gauge. Visually check oil level. Check filler cap and chip detector plug for security.

## 7. AREA 7 – TAILBOOM RIGHT SIDE

Tailboom – Condition.

Elevator – Condition and security.

Cargo compartment – Cargo secured, smoke detector condition, door secured.

## 8. AREA 8 – AFT FUSELAGE RIGHT SIDE

Fuselage – Check condition of skin.

Oil cooling fan compartment – Check condition of fan, flight control, and tail rotor servo for leaks. Check tailboom attachment bolts. Secure door.

• COPYRIGHT © 2007 BY EAGLE COPTERS MAINTENANCE LTD •

This document is private and confidential and is supplied on the express condition that it is not to be used for any purpose or copied or communicated to any other person without written permission from Eagle Copters Maintenance Ltd.

2<sup>nd</sup> tail rotor driveshaft – Check.

Heater compartment – Check heater for condition and security. Area clear of obstructions. Secure door.

Engine oil level – Verify presence of oil in sight gauge and proper oil level.

Engine compartment – Check fuel and oil lines and connections for condition, security and leaks. Check fluid levels. Secure cowling.

Fuel filler – Visually check quantity; secure cap.

## 9. AREA 9 – FUSELAGE RIGHT SIDE

Fuselage – Check condition of skin.

Passenger door – Check condition and operation; glass clean. Condition and security of pop-out windows.

Transmission oil level – Check.

Right Hydraulic Reservoir – Visually check fluid level

Landing gear – Condition; handling wheels removed.

Navigation and position lights – Security and condition.

## 10. AREA 10 – CABIN TOP



SNOW AND ICE SHALL BE REMOVED PRIOR TO FLIGHT  
WHEN HELICOPTER HAS BEEN EXPOSED TO SNOW AND  
ICING CONDITIONS.

• COPYRIGHT © 2007 BY EAGLE COPTERS MAINTENANCE LTD •

This document is private and confidential and is supplied on the express condition that it is not to be used for any purpose or copied or communicated to any other person without written permission from Eagle Copters Maintenance Ltd.

Anti-collision light – Condition and security.

Engine air intake – Cover removed. No damage or obstruction.

Main driveshaft and flexture – Condition, security.

Hydraulic reservoirs – Caps secured.

Transmission oil filler cap – Secured.

Hub and sleeve assembly – Check condition.

Main rotor and controls – Condition and fluid levels in dampers (2)

Main rotor pitch links – Security and condition.

Rotor blades – Visually check condition and cleanliness.

Engine and transmission cowling – Secured.

Antenna(s) – Condition and security.

## **2.4 Interior and Pre-start Check**

Main rotor and tail rotor tie-down – Stowed properly.

Pitot tube cover – Stowed properly.

Engine inlet and exhaust covers – Stowed properly.

Cabin interior – Cleanliness and security of equipment.

Cargo and baggage (if applicable) – Check security

• COPYRIGHT © 2007 BY EAGLE COPTERS MAINTENANCE LTD •

This document is private and confidential and is supplied on the express condition that it is not to be used for any purpose or copied or communicated to any other person without written permission from Eagle Copters Maintenance Ltd.

## Note

*Opening or removing doors shifts helicopter center of gravity and reduces  $V_{NE}$ . Refer to Section 1 and Section 5.*

Passenger doors – Secured or removed.

Passenger seats and belts – Check condition and security.

First aid kits – Check condition and security.

Protective breathing equipment (if required) – Condition and properly secured

### 2.4.1 Pre-start Check

Doors – Secured for flight.

Seats and pedals – Adjust.

Seat belts and shoulder harness – Fasten and adjusted.

Shoulder harness inertia reel and lock – Check.

Flight control frictions and lock – LOCK disengaged,  
– Set frictions as desired.

Flight controls – Verify freedom of movement. Center cyclic and pedals, collective full down.

Lower pedestal circuit breaker(s) – In.

Collective – All switches set

Defrost lever – As desired

• COPYRIGHT © 2007 BY EAGLE COPTERS MAINTENANCE LTD •

This document is private and confidential and is supplied on the express condition that it is not to be used for any purpose or copied or communicated to any other person without written permission from Eagle Copters Maintenance Ltd.



Altimeters(s) – Set

No. 1 and No. 2 HYDR SYS switches – ON.

FORCE TRIM switch – ON, cover down.

ENG DE-ICE switch – OFF.

START FUEL switch – OFF.

GOV AUTO/MANUAL switch – AUTO.

FUEL VALVE switch – OFF.

LH and RH BOOST PUMP switches – OFF.

Radios – As desired

S/Ns 30817, 30687 and 30599 Only

FIRE 1 PULL handle – In (forward)

Fire EXT switch – OFF, Cover down and safetied.

All S/Ns **EXCEPT** 30817, 30687 and 30599

ENG FIRE switch-lights NOT ILLUMINATED

FIRE EXTING switch-lights NOT ILLUMINATED, Covers down and safetied

• COPYRIGHT © 2007 BY EAGLE COPTERS MAINTENANCE LTD •

This document is private and confidential and is supplied on the express condition that it is not to be used for any purpose or copied or communicated to any other person without written permission from Eagle Copters Maintenance Ltd.

Note

*Inadvertent activation of either ENG FIRE switchlight will cause both EXTING switchlights to illuminate and arm the fire extinguishing system.*

Note

*The ENG FIRE switchlight is a latching system. To disarm the fire extinguishing system once armed, the same ENG FIRE switchlight must be pressed.*

AFT DOME LT rheostat and switch – OFF.

PITOT-STATIC HEATER switch – OFF.

CARGO REL switch – OFF.

WIPERS switch – OFF.

VENT BLOWER switch – OFF.

HEAT AFT OUTLET switch – OFF.

SYSTEM SELECTOR HEATER switch – OFF.

AVIONICS MASTER switches

ESS DC BUS switch – as desired

NON ESS DC BUS switch – as desired

Overhead Circuit Breakers – In/ON

Light rheostats (6) – OFF.

• COPYRIGHT © 2007 BY EAGLE COPTERS MAINTENANCE LTD •

This document is private and confidential and is supplied on the express condition that it is not to be used for any purpose or copied or communicated to any other person without written permission from Eagle Copters Maintenance Ltd.

ANTI-COLL light switch – BOTH

POSITION light switch – As Desired

STROBE LIGHT switch (if equipped) – As Desired

UTILITY LIGHT switch – OFF.

INV1 and INV2 switches – ON.

NON ESS BUS switch – MANUAL

GENERATOR switch – OFF.

BATTERY switch – ON.

LOW RPM AUDIO – OFF.

Note

*If EXTERNAL POWER is being used, BATTERY switch must be placed in the ON position to energize electrical systems.*

Note

*If external power (1000 amps maximum) is used adjust power source voltage to  $27 \pm 1$  VDC.*

DC Voltmeter – Greater than 24 VDC.

AC voltmeter – (S/Ns 30687, 30817 and 30599 only) 104 to 122 VAC.

AC voltage – (All **EXCEPT** S/Ns 30687, 30817 and 30599) – Verify both #1 and #2 inverter caution lights out.

Engine Instruments – Check gauges for proper indications.

• COPYRIGHT © 2007 BY EAGLE COPTERS MAINTENANCE LTD •

This document is private and confidential and is supplied on the express condition that it is not to be used for any purpose or copied or communicated to any other person without written permission from Eagle Copters Maintenance Ltd.

ENGINE RPM and ROTOR RPM warning light (LH and RH side) – Illuminated.

CARGO FIRE TEST switch – Test, verify lights flash

FIRE DETECTOR TEST switches (3) – Test.

FUEL QTY SEL switch – (S/N 30687) – LEFT, then RIGHT; verify fuel quantity gauge indicates lower fuel cell quantity of 270 to 300 pounds (each). Verify switch returns to center (TOT) position and indicator indicates total fuel on board.

FUEL QTY TEST switch – (All **EXCEPT** S/N 30687) – depress FUEL QTY TEST switch and verify fuel quantity indicator moves downscale toward zero. Release the switch and verify indicator moves upscale and stops when indicator indicates total fuel on board.

CARGO RELEASE armed light (if installed) – Test

Caution panel light test switch – TEST and RESET. Reset MASTER CAUTION light.

Note

*The following warning/caution segments should be illuminated:*

#1 HYD SYS

DC GENERATOR

EXT POWER (if receptacle door open)

LH FUEL BOOST

ENG OIL PRESS

XMSN OIL PRESS

#2 HYD SYS

RH FUEL BOOST

ENG FUEL PUMP

PAX DOOR LOCK

(if door open)

MASTER CAUTION TEST switch (overhead) – TEST; all caution panel segments extinguish except CAUTION PANEL and MASTER CAUTION lights on instrument panel.

• COPYRIGHT © 2007 BY EAGLE COPTERS MAINTENANCE LTD •

This document is private and confidential and is supplied on the express condition that it is not to be used for any purpose or copied or communicated to any other person without written permission from Eagle Copters Maintenance Ltd.



ROTOR BRAKE HANDLE (IF INSTALLED) SHALL BE IN DETENT POSITION (OFF) AT ALL TIMES WHEN ENGINE RUNNING.

ROTOR BRAKE LIGHTS (if installed) – Test. Pull brake lever and check that both lights illuminate; return to off and check lights extinguish.

HEATER switch – ON; Verify HEATER ON light illuminates.

Raise Collective until Bleed Air Priority switch actuates (HEATER OFF light illuminates, HEATER ON light extinguishes).

Lower Collective to the full down position, verify HEATER OFF light extinguishes and HEATER ON light illuminates.

HEATER switch – OFF.

NON ESS BUS switch – Normal

Light rheostats (6) – As Required.

GOV RPM switch – Decrease for 10 seconds.

• COPYRIGHT © 2007 BY EAGLE COPTERS MAINTENANCE LTD •

This document is private and confidential and is supplied on the express condition that it is not to be used for any purpose or copied or communicated to any other person without written permission from Eagle Copters Maintenance Ltd.

## 2.5 Engine Start

### Note

*The T5317A engine utilizes EGT and the T5317B/BCV engine utilizes MGT. The limitations for EGT and MGT are significantly different. Therefore, ensure the proper limitations are utilized during start and flight.*

### 2.5.1 Engine Start – Battery or Ground Power Unit

Rotor Blades – Clear.

LH and RH BOOST PUMP switches – ON. Verify LH FUEL BOOST and RH FUEL BOOST caution lights – Extinguish

FUEL VALVE switch – ON. Verify FUEL VALVE caution light illuminates momentarily, then extinguishes. Verify increase of fuel pressure on Fuel Pressure Indicator.

START FUEL switch – ON.

Throttle – Check travel, cushion and idle stop. Rotate throttle above idle stop. Press Idle Stop Release button and position throttle slightly below IDLE detent.

### Note

*Battery starts can be made when voltage less than 24 volts is indicated, provided voltage is not below 14 volts when cranking through 10 percent  $N_1$  speed.*

START switch – Select switch to START, start timing.

Main rotor – Check main rotor is turning by 15%  $N_1$ . If rotor is not turning, abort start.

• COPYRIGHT © 2007 BY EAGLE COPTERS MAINTENANCE LTD •

This document is private and confidential and is supplied on the express condition that it is not to be used for any purpose or copied or communicated to any other person without written permission from Eagle Copters Maintenance Ltd.

## Note

*If excessive EGT/MGT rise is about to occur, abort engine start by closing the throttle and continue to motor the engine with the starter until EGT/MGT decreases.*

EGT/MGT – Maintain within limits

START FUEL switch – Recommend OFF at 400°C (MGT or EGT) or 25% N<sub>1</sub>

## Note

*When helicopter has been cold soaked at temperatures below 0°C (32°F) the start may slow significantly if the START FUEL switch is turned off at 400°C. Therefore, the START FUEL may need to be left on above 400°C (MGT or EGT). It is recommended the START FUEL switch not be left on above 600°C (MGT) or 500°C (EGT) during start. Regardless of switch position, the ignition, starting fuel solenoid valve, and starter are de-energized to stop the flow of starting fuel and the starting fuel lines are purged at 40% N<sub>1</sub>.*

Start switch – OFF at 45% N<sub>1</sub> rpm

Engine Oil Pressure – Check increase in oil pressure.

Throttle – Slowly advance past the idle stop to engine IDLE position. Manually check idle stop by attempting to close throttle.

Gas Producer Tachometer indication – Verify indication is 71 ±1% N<sub>1</sub> RPM

Engine and Transmission Oil Pressures and Temperatures – Within Limits

Ground Power Unit – Disconnect

• COPYRIGHT © 2007 BY EAGLE COPTERS MAINTENANCE LTD •

This document is private and confidential and is supplied on the express condition that it is not to be used for any purpose or copied or communicated to any other person without written permission from Eagle Copters Maintenance Ltd.

GEN switch – RESET then ON

Loadmeter – Within Limits

START FUEL switch - ON

Caution Panel – All segments extinguished

AVIONICS MASTER switches – ON

## 2.5.2 Engine Fails to Start

When the engine fails to start within 15 seconds after the throttle has been opened to idle, the following action is recommended:

Throttle – Fully close.

Starter – Disengage.

After  $N_1$  has decreased to zero, allow 30 seconds for fuel to drain from engine.

## 2.6 Systems Check

### 2.6.1 Force Trim Check

FORCE TRIM switch – ON.

Flight controls – Friction off, collective lock removed.

Cyclic and pedals – Move slightly each direction to check force gradients.

Cyclic FORCE TRIM release button – Press. Check trim releases with button pressed, reengages with button released.

• COPYRIGHT © 2007 BY EAGLE COPTERS MAINTENANCE LTD •

This document is private and confidential and is supplied on the express condition that it is not to be used for any purpose or copied or communicated to any other person without written permission from Eagle Copters Maintenance Ltd.

FORCE TRIM switch – OFF. Check trim disengages.

FORCE TRIM switch – ON.

## 2.6.2 Preliminary Hydraulic Check

FORCE TRIM switch – OFF.

Throttle – Set to idle.

### Note

*Uncommanded control movement or motoring with either hydraulic system off may indicate hydraulic system malfunction.*

HYDR SYS NO. 1 switch – OFF, then ON.

HYDR SYS NO. 2 switch – OFF, then ON.

FORCE TRIM switch – ON.

## 2.6.3 Engine Fuel Control

Throttle – Idle

GOV switch – MANUAL, verify GOV MANUAL caution light illuminates  
Verify  $N_1$  decreases, do not allow  $N_1$  to go below 45%  
Check engine response with throttle

Throttle – IDLE.

GOV switch – AUTO, verify GOV MANUAL caution light extinguishes.  
Verify  $N_1$  returns to original idle rpm.

• COPYRIGHT © 2007 BY EAGLE COPTERS MAINTENANCE LTD •

This document is private and confidential and is supplied on the express condition that it is not to be used for any purpose or copied or communicated to any other person without written permission from Eagle Copters Maintenance Ltd.

## 2.6.4 Rpm Control

Collective – Full down.

Throttle – Full open.

GOV RPM INCR/DECR switch – Check operation between 97 and 100%  $N_2 \pm 1\%$ .  
Set to 100%.

Note

*When  $N_2$  is below  $89 \pm 1\%$ , the ENGINE RPM light will illuminate RED and audio signal will activate.*

Note

*When the rotor RPM is below 97%, the ROTOR RPM light will illuminate AMBER and the audio signal will activate.*

## 2.6.5 Anti-ice Check

ENG DE-ICE switch – ON, verify MGT/EGT increase.  
Verify ENG DE-ICE ON caution light illuminates.

ENG DE-ICE switch – OFF, verify MGT/EGT decrease.  
Verify ENG DE-ICE ON caution light extinguishes.

## 2.6.6 Electrical System Checks

#2 INVERTER Check

• COPYRIGHT © 2007 BY EAGLE COPTERS MAINTENANCE LTD •

This document is private and confidential and is supplied on the express condition that it is not to be used for any purpose or copied or communicated to any other person without written permission from Eagle Copters Maintenance Ltd.

INV 1 – OFF

AC Voltmeter 104 to 122 VAC (if installed).  
#1 INVERTER caution light illuminates

INV 1 – ON

AC Voltmeter 104 to 122 VAC (if installed).  
#1 INVERTER caution light extinguishes

DC Voltmeter – Indicates  $28 \pm 1$  VDC.

For all S/Ns **EXCEPT** 30817, 30687 and 30599

GCU Check.

GCU TEST switch - OVERVOLTAGE, DC GENERATOR light on and DC generator  
offline

GCU TEST switch - center

GEN switch - RESET and then ON, DC GENERATOR light OFF

GCU TEST switch - OVERLOAD, DC GENERATOR light ON

GCU TEST switch - center

GEN switch - RESET and then ON, DC GENERATOR light OFF.

PITOT HTR – Check. Place PITOT HTR switch in ON position. Note Loadmeter increase. Return to OFF position.

## 2.6.7 Hydraulic System Checks

### Note

*This check is to determine proper operation of hydraulic actuators for each flight control system. If abnormal forces, unequal forces, control binding or motoring is encountered, it may be an indication of a malfunction of a flight control actuator.*

FORCE TRIM switch – OFF.

Collective – Down, friction removed.

• COPYRIGHT © 2007 BY EAGLE COPTERS MAINTENANCE LTD •

This document is private and confidential and is supplied on the express condition that it is not to be used for any purpose or copied or communicated to any other person without written permission from Eagle Copters Maintenance Ltd.

ROTOR RPM (N<sub>R</sub>) – Set to 100%

Cyclic – Centered, friction removed.

Hydraulic System – Check as follows:

HYDR SYS NO. 1 switch – OFF. Check MASTER CAUTION light illuminates and #1 HYDR SYST caution light illuminates. Hydraulic system no. 1 pressure decreases.

Cyclic – Check normal operation by moving cyclic in an “X” pattern, right forward to left aft, then left forward to right aft (approximately 1 inch). Center cyclic.

Collective – Check normal operation by increasing collective slightly (1 to 2 inches). Return to down position.

#### Note

*Boost for tail rotor controls is furnished by hydraulic system no. 1 only. When hydraulic system no. 1 is being checked, tail rotor controls will be unboosted.*

Pedals – Displace slightly left and right. Note an increase in force required to move pedals.

#### Warning

**DO NOT TURN BOTH HYDRAULIC SYSTEMS OFF AT SAME TIME DUE TO EXCESSIVE FORCE REQUIRED TO MOVE FLIGHT CONTROLS.**

HYDR SYS NO. 1 switch – ON. Check MASTER CAUTION light extinguishes and hydraulic system no. 1 pressure returns to normal. #1 HYDR SYST caution light

• COPYRIGHT © 2007 BY EAGLE COPTERS MAINTENANCE LTD •

This document is private and confidential and is supplied on the express condition that it is not to be used for any purpose or copied or communicated to any other person without written permission from Eagle Copters Maintenance Ltd.

extinguishes.

HYDR SYS NO. 2 switch – OFF. Check MASTER CAUTION light illuminates and hydraulic system no. 2 pressure decreases. #2 HYDR SYST caution light illuminates.

Cyclic – Check normal operation of cyclic controls by moving cyclic in an “X” pattern, right forward to left aft, then left forward to right aft (approximately 1 inch). Center cyclic.

Collective – Check normal operation by increasing collective slightly (1 to 2 inches). Return to down position.

Pedals – Displace slightly left and right. Note no increase in force required to move pedals.

HYDR SYS NO. 2 switch – ON. Check MASTER CAUTION light extinguishes and hydraulic system no. 2 pressure returns to normal. #2 HYDR SYST caution light extinguishes.

Cyclic and collective friction – As desired

FORCE TRIM switch – ON

**WARNING**

**BOTH HYDRAULIC SYSTEMS SHALL BE OPERATIONAL  
PRIOR TO TAKEOFF.**

Note

*System 1 will normally operate 10 to 20°C cooler than System 2.*

• COPYRIGHT © 2007 BY EAGLE COPTERS MAINTENANCE LTD •

This document is private and confidential and is supplied on the express condition that it is not to be used for any purpose or copied or communicated to any other person without written permission from Eagle Copters Maintenance Ltd.

## 2.6.8 Cabin Heater Check

VENT BLOWER switch – OFF.



DO NOT OPERATE HEATER ABOVE 21°C (69.8°F) OAT.

SYSTEM SELECTOR switch – HEATER. Verify HEATER ON light illuminates. Check heater airflow from pedestal outlets.

DEFROSTER lever – Forward position (on). Check airflow is diverted from pedestal outlets to windshield nozzles. Return lever to aft position (off).

VENT BLOWER and HEATER switches – As desired.

## 2.7 Before Takeoff

Flight instruments – Check and set.

Throttle – FULL OPEN, N<sub>2</sub>/N<sub>R</sub> – 100%

Engine, transmission, hydraulic and electrical instruments – Within operating ranges.

Cautions and warnings – Extinguished.

FORCE TRIM switch – As desired.

Avionics – check functioning.

PITOT HEATER switch – As required.

Passenger seat belts – Fastened.

• COPYRIGHT © 2007 BY EAGLE COPTERS MAINTENANCE LTD •

This document is private and confidential and is supplied on the express condition that it is not to be used for any purpose or copied or communicated to any other person without written permission from Eagle Copters Maintenance Ltd.

All doors – Secured.

Throttle friction – Apply

Cyclic and collective control – Friction as desired

## 2.8 Takeoff

Cyclic control – Neutral or slightly into the wind.

Collective – Increase to attain a hover altitude of four feet.

### Note

*The bleed air heater valve will automatically shut off at high collective. The heater OFF light will illuminate momentarily as the bleed air valve closes. If the bleed air valve malfunctions the heater OFF light will remain illuminated.*

Pedals – apply pressure to maintain heading.

Cyclic control – Apply forward cyclic to accelerate smoothly while increasing torque. For proper maximum torque refer to Power Limits for Takeoff, Section 1.

Maintain an altitude of 7 ft until 30 kias.

At 40 KIAS, adjust the pitch attitude to attain 65 KIAS and 30 feet AGL.

Adjust power as required up to takeoff power to obtain necessary rate of climb after obtaining 65 KIAS.

• COPYRIGHT © 2007 BY EAGLE COPTERS MAINTENANCE LTD •

This document is private and confidential and is supplied on the express condition that it is not to be used for any purpose or copied or communicated to any other person without written permission from Eagle Copters Maintenance Ltd.

## 2.9 In-Flight Operation

ENG – 97 to 100% N<sub>2</sub>

Airspeed – Within limits for flight altitude and gross weight

Engine, transmission, hydraulic and electrical instruments – Within limits.

ENG DE-ICE switch – As required.

### Note

*When ambient temperature is below 4.4°C (40°F) during visible moisture (rain, snow or fog), position ENG DE-ICE switch ON.*

## 2.10 Descent and Landing

Flight controls – adjust friction as desired.

Throttle – FULL OPEN.

N<sub>R</sub> – 100%

FORCE TRIM switch – as desired.

### Note

*For extended ground operations (exceeding 2 minutes), N<sub>1</sub> speed should be maintained at or above 74%.*

• COPYRIGHT © 2007 BY EAGLE COPTERS MAINTENANCE LTD •

This document is private and confidential and is supplied on the express condition that it is not to be used for any purpose or copied or communicated to any other person without written permission from Eagle Copters Maintenance Ltd.

## 2.11 After Landing

Collective pitch – Full down.

Cyclic and pedals – Centered.

Throttle – Reduce to engine idle. Allow EGT/MGT to stabilize for two minutes.

LOW RPM AUDIO switch – OFF.

FORCE TRIM switch – ON

Control frictions – As desired

PITOT-STATIC HEATER switch – OFF.

Nonessential equipment – OFF

ELT – Check for inadvertent transmission.

## 2.12 Engine Shutdown

Throttle – Press and hold ENG IDLE STOP REL. Close throttle.



IF A RAPID RISE IN EGT/MGT IS NOTED, ENGAGE STARTER SWITCH TO MOTOR ENGINE (THROTTLE CLOSED), STABILIZING TEMPERATURE WITHIN LIMITS.

FUEL VALVE switch – OFF.

LH and RH BOOST PUMP switches – OFF.

• COPYRIGHT © 2007 BY EAGLE COPTERS MAINTENANCE LTD •

This document is private and confidential and is supplied on the express condition that it is not to be used for any purpose or copied or communicated to any other person without written permission from Eagle Copters Maintenance Ltd.

START FUEL switch – OFF

ENG DE-ICE switch – OFF.

GEN switch – OFF.

INV 1 and INV 2 – OFF.



**DO NOT USE COLLECTIVE OR PEDALS TO SLOW ROTOR RPM. USE OF COLLECTIVE OR PEDALS TO SLOW ROTOR RPM CAN CAUSE EXCESSIVE FLAPPING AND/OR CONING.**

AVIONICS MASTER switches – OFF.

Pilot – Remain at flight controls until rotor has come to a complete stop.

Collective – All switches OFF.

Lighting and miscellaneous switches – OFF.

BATTERY switch – OFF.

Collective down lock – Secured as desired.

• COPYRIGHT © 2007 BY EAGLE COPTERS MAINTENANCE LTD •

This document is private and confidential and is supplied on the express condition that it is not to be used for any purpose or copied or communicated to any other person without written permission from Eagle Copters Maintenance Ltd.

## 2.13 Post Flight Check

Main rotor and tail rotor blades – Tiedown when any of the following conditions exist:

Thunderstorms exist in local area or are forecast.

Winds in excess of 20 knots or a gust spread of 15 knots exist or is forecast.

Helicopter is parked within 150 feet of hovering or taxiing aircraft that are in excess of basic helicopter GW.

Helicopter is to be left unattended.

Protective covers (engine exhaust and pitot tube) – Install.

• COPYRIGHT © 2007 BY EAGLE COPTERS MAINTENANCE LTD •

This document is private and confidential and is supplied on the express condition that it is not to be used for any purpose or copied or communicated to any other person without written permission from Eagle Copters Maintenance Ltd.

# Section 3

## Emergency Procedures

### Table of Contents

|       |  |    |
|-------|--|----|
| 3.1   | Introduction.....                                    | 3  |
| 3.2   | Definitions.....                                     | 3  |
| 3.3   | Engine .....   | 4  |
| 3.3.1 | Engine Failure                                       | 4  |
| 3.3.2 | Engine Restart in Flight                             | 5  |
| 3.3.3 | Engine Driveshaft/Clutch Failure                     | 7  |
| 3.3.4 | Engine Underspeed                                    | 8  |
| 3.3.5 | Engine Overspeed                                     | 9  |
| 3.3.6 | Engine Compressor Stall                              | 10 |
| 3.3.7 | Engine Hot Start/Shutdown                            | 10 |
| 3.4   | Fire .....   | 11 |
| 3.4.1 | Engine Fire (S/Ns 30817, 30687 and 30599)            | 11 |
| 3.4.2 | Engine Fire (All S/Ns EXCEPT 30817, 30687 and 30599) | 12 |
| 3.4.3 | Cabin Smoke or Fumes                                 | 14 |
| 3.4.4 | Cargo Compartment Fire                               | 14 |
| 3.5   | Tail Rotor.....                                      | 14 |
| 3.5.1 | Complete Loss of Tail Rotor Thrust                   | 15 |
| 3.5.2 | Loss of Tail Rotor Components                        | 18 |
| 3.5.3 | Tail Rotor Fixed Pitch Failures                      | 18 |
| 3.5.4 | Fixed Pitch Failure at a Hover                       | 18 |
| 3.5.5 | Fixed Pitch Failure in Flight                        | 18 |
| 3.5.6 | Loss of Pitch Change Control Linkage                 | 20 |
| 3.6   | Hydraulic System .....                               | 21 |
| 3.7   | Electrical System.....                               | 21 |
| 3.7.1 | Generator Failure                                    | 21 |
| 3.8   | Fuel System .....                                    | 22 |
| 3.8.1 | Fuel boost pump failure                              | 22 |
| 3.8.2 | Fuel Filter Partially Blocked                        | 23 |
| 3.8.3 | Fuel Quantity Indication Malfunctions                | 23 |
| 3.9   | Communications System .....                          | 23 |

• COPYRIGHT © 2007 BY EAGLE COPTERS MAINTENANCE LTD •

This document is private and confidential and is supplied on the express condition that it is not to be used for any purpose or copied or communicated to any other person without written permission from Eagle Copters Maintenance Ltd.

Revision: **M**

Date: 2026-04-13

TCCA Approved



|       |   |    |
|-------|---|----|
| 3.9.1 | Intercom Failure                          | 23 |
| 3.10  | Cabin Heater .....                        | 24 |
| 3.11  | Warning and Caution Lights Messages ..... | 25 |

### List of Tables

|           |                               |      |
|-----------|-------------------------------|------|
| Table 3-1 | Warning Segments (Red).....   | 3-26 |
| Table 3-2 | Caution Segments (Amber)..... | 3-28 |

• COPYRIGHT © 2007 BY EAGLE COPTERS MAINTENANCE LTD •

This document is private and confidential and is supplied on the express condition that it is not to be used for any purpose or copied or communicated to any other person without written permission from Eagle Copters Maintenance Ltd.

TCCA Approved

Revision: **M**

Date: 2026-04-13

## Section 3

### *Emergency Procedures*

#### **3.1 Introduction**

Following procedures contain indications of equipment or system failure or malfunction, use of emergency features of primary and backup systems, and appropriate warnings, cautions, and explanatory notes. Table 3-1 lists fault conditions and corrective actions required for illumination of red warning lights. Table 3-2 addresses malfunction procedures associated with yellow caution lights.

Corrective action procedures listed herein assume pilot gives first priority to helicopter control and a safe flight path.

Helicopter should not be operated following any precautionary landing until cause of malfunction has been determined and corrective maintenance action taken.

#### **3.2 Definitions**

Following terms indicate degree of urgency in landing helicopter.

**LAND AS SOON AS POSSIBLE** – Land without delay at nearest suitable area (i.e. open field) at which a safe approach and landing is reasonably assured.

**LAND AS SOON AS PRACTICAL** – Duration of flight and landing site are at discretion of pilot. Extended flight beyond nearest approved landing area is not recommended.

**LAND IMMEDIATELY** – The urgency of landing is paramount. The primary consideration is to ensure the survival of the occupants. Landing in water, trees or other unsafe area should be considered only as a last resort.

Following terms are used to describe operating condition of a system, subsystem,

• COPYRIGHT © 2007 BY EAGLE COPTERS MAINTENANCE LTD •

This document is private and confidential and is supplied on the express condition that it is not to be used for any purpose or copied or communicated to any other person without written permission from Eagle Copters Maintenance Ltd.

assembly, or component:

AFFECTED – Fails to operate in intended or usual manner.

NORMAL – Operates in the intended or usual manner.

## 3.3 Engine

### 3.3.1 Engine Failure

#### 3.3.1.1 Engine Failure – Hovering

Indications:

1. Left Yaw
2. ENGINE RPM warning lights illuminated ( $N_2$  below  $89 \pm 1\%$ )
3. ROTOR RPM caution lights illuminated ( $N_R$  below 97%)
4. Rotor RPM audio tone
5. ENG OIL PRESS and DC GENERATOR caution lights may be illuminated

Procedure:

1. Maintain heading and attitude control.
2. Collective – Adjust to control  $N_R$  and rate of descent.  
Increase prior to ground contact to cushion landing.

Note

*The magnitude and rate of collective movement is a function of height above ground. Any forward airspeed will aid in ability to cushion landing.*

3. Land.
4. Complete shut down.

#### 3.3.1.2 Engine Failure – In flight

Indications:

1. Left yaw.

• COPYRIGHT © 2007 BY EAGLE COPTERS MAINTENANCE LTD •

This document is private and confidential and is supplied on the express condition that it is not to be used for any purpose or copied or communicated to any other person without written permission from Eagle Copters Maintenance Ltd.

2. ENGINE RPM warning lights illuminate ( $N_2$  below  $89 \pm 1\%$ )
3. ROTOR RPM caution lights illuminated ( $N_R$  below 97%)
4. ENG OIL PRESS and DC GENERATOR caution lights may be illuminated

Procedure:

Note

*Minimum rate of descent airspeed is 65 KIAS and maximum glide distance airspeed is 85 KIAS.*

1. Collective – Establish autorotative descent  
Adjust to maintain proper  $N_R$
2. Airspeed – Establish 65 to 85 KIAS
3. Attempt engine restart if desired, refer to ENGINE RESTART, paragraph 3.3.2

*If engine restart is not attempted or not successful:*

4. Throttle – Closed
5. FUEL VALVE – OFF.

*At low altitude:*

6. Flare to lose airspeed
7. Apply collective as flare effectiveness decreases to further reduce forward speed and cushion landing.
8. Upon ground contact, collective shall be reduced smoothly while maintaining cyclic approximately centered
9. Complete helicopter shutdown.

### 3.3.2 Engine Restart in Flight

An engine restart may be attempted in flight if time and altitude permit.  
Restart in flight is not recommended unless above 3000 ft. AGL.

• COPYRIGHT © 2007 BY EAGLE COPTERS MAINTENANCE LTD •

This document is private and confidential and is supplied on the express condition that it is not to be used for any purpose or copied or communicated to any other person without written permission from Eagle Copters Maintenance Ltd.



IF CAUSE OF FAILURE IS OBVIOUSLY MECHANICAL, AS EVIDENCED BY ABNORMAL METALLIC OR GRINDING SOUNDS, DO NOT ATTEMPT A RESTART.

Procedure:

Note

*Minimum rate of descent airspeed of 65 KIAS and will allow the pilot more time for air start.*

1. Collective – Establish autorotative descent  
Adjust to maintain  $N_R$ .
2. AIRSPEED – Establish 65 KIAS
3. Throttle – Decrease to top of idle stop
4. Fuel – ON
5. START FUEL switch – ON
6. Battery – Verify ON
7.  $N_1$  – Verify 25% or less
8. Starter switch – Switch to START position.
9.  $N_1$  and EGT/MGT – Observe for engine start indication.
10. START FUEL switch – OFF at 400°C (MGT or EGT).
11. Starter – OFF at 45%  $N_1$
12. Throttle – Open slowly to normal operational RPM
13. Engine oil pressure and temperature – Within limits.
14. Generator – RESET, then ON
15. START FUEL switch – ON
16. Land as soon as possible

• COPYRIGHT © 2007 BY EAGLE COPTERS MAINTENANCE LTD •

This document is private and confidential and is supplied on the express condition that it is not to be used for any purpose or copied or communicated to any other person without written permission from Eagle Copters Maintenance Ltd.

TCCA Approved

Revision: **M**

Date: 2026-04-13

### 3.3.3 Engine Driveshaft/Clutch Failure

|                |
|----------------|
| <b>WARNING</b> |
|----------------|

**FAILURE OF MAIN DRIVESHAFT TO TRANSMISSION WILL RESULT IN COMPLETE LOSS OF POWER TO THE MAIN ROTOR. ALTHOUGH COCKPIT INDICATIONS FOR A DRIVESHAFT FAILURE ARE SIMILAR TO AN ENGINE OVERSPEED, IT IS IMPERATIVE THAT AUTOROTATIVE FLIGHT PROCEDURES BE ESTABLISHED IMMEDIATELY. FAILURE TO REACT IMMEDIATELY TO ROTOR RPM AUDIO, ROTOR RPM LIGHTS AND  $N_2/N_R$  TACHOMETER INDICATIONS CAN RESULT IN LOSS OF CONTROL OF THE HELICOPTER.**

Indications:

1. Left yaw
2. Rapid decrease in  $N_R$
3. ROTOR RPM audio tone
4. Illumination of ROTOR RPM light
5. Possible increase in noise level due to driveshaft breakage and overspeeding engine.

Procedure:

1. Collective – Establish autorotative descent.  
Adjust to maintain proper  $N_R$
2. Airspeed – Establish 65 to 85 KIAS
3. Throttle – Close
4. FUEL VALVE Switch – OFF.

*At low altitude:*

5. Flare to lose airspeed
6. Apply collective as flare effectiveness decreases to further reduce forward speed and cushion landing.
7. Upon ground contact, collective shall be reduced smoothly while maintaining

• COPYRIGHT © 2007 BY EAGLE COPTERS MAINTENANCE LTD •

This document is private and confidential and is supplied on the express condition that it is not to be used for any purpose or copied or communicated to any other person without written permission from Eagle Copters Maintenance Ltd.

Revision: **M**

Date: 2026-04-13

TCCA Approved

- cyclic approximately centered
8. Complete helicopter shutdown.

### 3.3.4 Engine Underspeed

An engine underspeed is caused by a malfunctioning N<sub>2</sub> governor. At low altitude/low airspeed, the malfunction must be treated as an engine failure because of insufficient time and altitude to regain normal engine rpm with MANUAL governor control.

Indications:

1. ROTOR RPM caution light and audio on
2. ENGINE RPM warning light on.
3. Low N<sub>1</sub>, EGT/MGT and engine torque

Procedure:



**IF CORRECTIVE ACTION IS NOT INITIATED IMMEDIATELY,  
ROTOR RPM COULD DECAY EXCESSIVELY.**

Note

*Because automatic acceleration, deceleration and overspeed controls are not provided with the GOV switch in the MANUAL position, throttle and collective movements must be smooth to prevent overspeed, over-temperature or engine failure.*

*If an underspeed is experienced and altitude permits, proceed as follows:*

1. Collective – Establish autorotative descent  
Adjust to maintain proper N<sub>R</sub>
2. Throttle – Engine IDLE.
3. GOV switch – MANUAL.

• COPYRIGHT © 2007 BY EAGLE COPTERS MAINTENANCE LTD •

This document is private and confidential and is supplied on the express condition that it is not to be used for any purpose or copied or communicated to any other person without written permission from Eagle Copters Maintenance Ltd.

4. Throttle – Open slowly to normal operating rpm and continue flight with manual throttle control.
5. MASTER CAUTION light – Reset.
6. Land as soon as possible.

### 3.3.5 Engine Overspeed

An engine overspeed is caused by a malfunctioning N<sub>2</sub> Governor.

Indications:

1. Illumination of ROTOR RPM caution lights
2. Possible increase in noise due to overspeeding engine turbines or driveshaft.
3. Possible illumination of ENGINE RPM warning lights



IF CORRECTIVE ACTION IS NOT INITIATED THE MAIN ROTOR AND ENGINE MAY OVERSPEED EXCESSIVELY.

Procedure:

1. Collective – Increase to control N<sub>2</sub>/N<sub>R</sub> speed
2. Throttle – Reduce until N<sub>2</sub>/N<sub>R</sub> are within limits
3. Collective – DOWN; establish autorotational glide when conditions permit.
4. Throttle – IDLE.
5. GOV switch – MANUAL.



WHEN OPERATING IN MANUAL FUEL CONTROL MODE, MAKE SLOW SMOOTH, AND COORDINATED THROTTLE AND COLLECTIVE MOVEMENTS THIS WILL HELP TO AVOID COMPRESSOR STALL, OVERTEMP,

• COPYRIGHT © 2007 BY EAGLE COPTERS MAINTENANCE LTD •

This document is private and confidential and is supplied on the express condition that it is not to be used for any purpose or copied or communicated to any other person without written permission from Eagle Copters Maintenance Ltd.

## UNDERSPEED/OVERSPEED, AND POSSIBLE DRIVETRAIN DAMAGE.

6. Throttle – Open slowly to normal operational RPM and continue flight with manual throttle control.
7. MASTER Caution – Reset.
8. Land as soon as possible

### 3.3.6 Engine Compressor Stall

Engine compressor stall (surge) is characterized by a sharp rumble or a series of loud, sharp reports, severe engine vibration, and a rapid rise in EGT/MGT depending on the severity of the surge. Maneuvers requiring rapid or maximum power applications should be avoided.

#### Indications:

1. Engine 'pops'.
2. High or erratic EGT/MGT.
3. Decreasing or erratic N<sub>1</sub> and N<sub>2</sub> RPM.
4. Torque oscillations.

#### Procedure:

1. Collective – Reduce power; maintain slow flight.
2. ENG DE-ICE switch – OFF.
3. HEATER SYSTEM SELECTOR switch – OFF.
4. If stall continues, land as soon as practical.
5. After landing, accomplish normal shut-down.

### 3.3.7 Engine Hot Start/Shutdown

A hot start is caused by a combination of excessive fuel in the combustion chamber and delayed fuel ignition. Internal and external damage can result.

• COPYRIGHT © 2007 BY EAGLE COPTERS MAINTENANCE LTD •

This document is private and confidential and is supplied on the express condition that it is not to be used for any purpose or copied or communicated to any other person without written permission from Eagle Copters Maintenance Ltd.

**Indications:**

1. Flames emitting from the exhaust.
2. Excessive EGT/MGT indication.

**Procedure:**

1. Throttle – Closed; keep starter engaged.
2. FUEL VALVE switch – OFF.
3. START FUEL – OFF.
4. Starter – continue to energize until EGT/MGT decreases below approximately 150°C.
5. Complete shutdown.

If EGT/MGT limits for starting were exceeded, refer to Engine Maintenance Manual for inspection requirements.

## **3.4 Fire**

### **3.4.1 Engine Fire (S/Ns 30817, 30687 and 30599)**

#### **3.4.1.1 During Start**

**Indications:**

1. FIRE 1 PULL handle illuminated.
2. Fire observed in or around engine compartment.

**Procedure:**

1. Throttle – Close.
2. FIRE 1 PULL handle – PULL.
3. EXTING switch – EXTINGUISH.
4. FUEL VALVE switch – OFF.
5. BAT switch – OFF.
6. Helicopter – Exit.

• COPYRIGHT © 2007 BY EAGLE COPTERS MAINTENANCE LTD •

This document is private and confidential and is supplied on the express condition that it is not to be used for any purpose or copied or communicated to any other person without written permission from Eagle Copters Maintenance Ltd.

### 3.4.1.2 During Low Altitude Flight

Indications:

1. FIRE 1 PULL handle illuminated.

Procedure:

1. FIRE 1 PULL handle – PULL.
2. EXTING switch – EXTINGUISH.
3. Land immediately.
4. Throttle – Close.
5. FUEL VALVE switch – OFF.
6. BAT switch – OFF.
7. Helicopter – Exit.

### 3.4.1.3 In Flight

Indications:

1. FIRE 1 PULL handle illuminated.

Procedure:

1. Emergency descent – Initiate immediately, if possible.
2. FIRE 1 PULL handle – PULL.
3. EXTING switch – EXTINGUISH.
4. Land immediately.
5. Throttle – Close.
6. FUEL VALVE switch – OFF.
7. BAT switch – OFF.
8. Helicopter – Exit.

## 3.4.2 Engine Fire (All S/Ns EXCEPT 30817, 30687 and 30599)

### 3.4.2.1 During Start

Indications:

1. ENGINE FIRE switch-lights illuminated (both)
2. Fire observed in or around engine compartment.

• COPYRIGHT © 2007 BY EAGLE COPTERS MAINTENANCE LTD •

This document is private and confidential and is supplied on the express condition that it is not to be used for any purpose or copied or communicated to any other person without written permission from Eagle Copters Maintenance Ltd.

Procedure:

1. Throttle – close.
2. ENGINE FIRE switch-light – PRESS to arm (Either switch).
3. FIRE EXTING switch-light – Lift cover, PRESS (Either switch).
4. FUEL VALVE switch – OFF.
5. BAT switch – OFF.
6. Helicopter – Exit.

### 3.4.2.2 During Low Altitude Flight

Indications:

1. ENGINE FIRE switch-lights illuminated (both).

Procedure:

1. ENGINE FIRE switch-light – PRESS to arm (Either switch).
2. FIRE EXTING switch-light – Lift cover, PRESS (Either switch).
3. Land immediately.
4. Throttle – Close.
5. FUEL VALVE switch – OFF.
6. BAT switch – OFF.
7. Helicopter – Exit.

### 3.4.2.3 In Flight

Indications:

1. ENGINE FIRE switch-lights illuminated (both).

Procedure:

1. Emergency descent – initiate immediately, if possible.
2. ENGINE FIRE switch-light – PRESS to arm (Either switch).
3. FIRE EXTING switch-light – Lift cover, PRESS (Either switch).
4. Land immediately.
5. Throttle – Close.
6. FUEL VALVE switch – OFF.
7. BAT switch – OFF.
8. Helicopter – Exit.

• COPYRIGHT © 2007 BY EAGLE COPTERS MAINTENANCE LTD •

This document is private and confidential and is supplied on the express condition that it is not to be used for any purpose or copied or communicated to any other person without written permission from Eagle Copters Maintenance Ltd.

Revision: **M**

Date: 2026-04-13

TCCA Approved

### 3.4.3 Cabin Smoke or Fumes

Indications:

1. Smoke, toxic fumes etc., in cabin.

Procedure:

1. VENT BLOWER switch – ON
2. Vents and accessible windows – Open.

*If additional ventilation is required:*

1. Airspeed – Reduce to 60 KIAS or less.
2. Passenger doors, windows, vents – Open.

*If time and altitude permit and source is suspected to be electrical:*

1. Affected system – Attempt to identify and isolate.
2. Land as soon as possible.

### 3.4.4 Cargo Compartment Fire

Indications:

1. CARGO FIRE warning light illuminated.

Procedure:

1. Reduce power to minimum required.
2. Land as soon as possible.
3. Inspect tailboom area for damage.

## 3.5 Tail Rotor

Note

*The key to successful handling of a tail rotor emergency lies in pilot ability to quickly recognize type of malfunction and to select proper emergency procedure. Following is a discussion of some types of tail rotor malfunctions and their probable effects.*

• COPYRIGHT © 2007 BY EAGLE COPTERS MAINTENANCE LTD •

This document is private and confidential and is supplied on the express condition that it is not to be used for any purpose or copied or communicated to any other person without written permission from Eagle Copters Maintenance Ltd.

### 3.5.1 Complete Loss of Tail Rotor Thrust

#### Indication:

This is a situation involving a break in drive system, such as a severed driveshaft, wherein tail rotor stops turning and delivers no thrust. A failure of this type in powered flight will result in nose of helicopter swinging to right (left side slip) and usually a roll of fuselage. Nose down attitude may also be present. Severity of initial reaction will be affected by airspeed,  $H_D$ , GW, CG and power being used.

#### 3.5.1.1 Loss of Tail Rotor Thrust at Hover

##### Procedure:

Close throttle immediately and make a hovering autorotation landing. Yawing can be expected on touchdown.

#### 3.5.1.2 Loss of Tail Rotor Thrust in Climb

Degree of right yaw upon failure will be greater than that expected in level flight due to higher power and antitorque settings.

##### Procedure:

Close throttle and lower collective immediately. Establish a glide speed slightly above normal autorotation approach speed.

If a turn is required to reach a more desirable place to land or to align into wind, make it to right if possible. A turn to right can be more nearly streamlined by use of a little power.

Once aligned for landing, yaw can be controlled in the following manner:

#### Right Yaw

If nose yaws right with power off, a pulse of up collective will produce more friction in mast thrust bearings, creating a left moment. The greater the input of pulse, the more the response will be.

• COPYRIGHT © 2007 BY EAGLE COPTERS MAINTENANCE LTD •

This document is private and confidential and is supplied on the express condition that it is not to be used for any purpose or copied or communicated to any other person without written permission from Eagle Copters Maintenance Ltd.

**WARNING**

**DO NOT ALLOW ROTOR RPM TO DECAY BELOW MINIMUM LIMITS.**

• COPYRIGHT © 2007 BY EAGLE COPTERS MAINTENANCE LTD •

This document is private and confidential and is supplied on the express condition that it is not to be used for any purpose or copied or communicated to any other person without written permission from Eagle Copters Maintenance Ltd.

TCCA Approved

Revision: **M**

Date: 2026-04-13

Moving collective upward abruptly increases rotor loading. Do not hold collective up as rotor rpm will decrease lower than desirable. It is essential that collective be returned to down position for autorotation. This cycle is one pulse. Pulse should be rapid (up and down) but should not be used at low altitudes.

### Left Yaw

If the nose yaws left with power off, a slight addition of power should arrest it. Further increases in power results in more right yaw increase.

### Landing

During final stages of approach, a mild flare should be executed and all power to rotor should be off. Maintain helicopter in a slight flare and use collective smoothly to execute a soft, slightly nose high landing. Landing on aft portion of skids will tend to correct side drift. If helicopter starts to turn, move cyclic as necessary to follow turn until the helicopter comes to a complete stop. This technique will, in most cases, result in a run on type landing.

**CAUTION**

FOR ZERO GROUND SPEED LANDING, FLARE AND ABRUPT USE OF COLLECTIVE MAY CAUSE NOSE TO YAW LEFT. DO NOT CORRECT WITH THROTTLE. ALTHOUGH APPLICATION OF THROTTLE WILL RESULT IN YAWING TO THE RIGHT, ADDITION OF POWER IS A VERY STRONG RESPONSE MEASURE AND IS TOO SENSITIVE FOR PILOT TO MANAGE PROPERLY. DO NOT ADD POWER AT THIS TIME. SLIGHT YAWING UPON TOUCHDOWN AT ZERO GROUND SPEED MAY BE EXPECTED.

### 3.5.1.3 Loss of Tail Rotor Thrust in Level Flight or Descent Procedures:

• COPYRIGHT © 2007 BY EAGLE COPTERS MAINTENANCE LTD •

This document is private and confidential and is supplied on the express condition that it is not to be used for any purpose or copied or communicated to any other person without written permission from Eagle Copters Maintenance Ltd.

Close throttle and reduce collective immediately. Attain an airspeed slightly above normal autorotative glide speed.

If altitude permits with AIRSPEED above 60 KIAS, throttle and collective may be gently applied to determine if some degree of powered flight can be resumed. If unacceptable yawing is experienced, re-enter autorotation and continue descent to a landing.

Landing technique is same as prescribed for climb condition above.

### 3.5.2 Loss of Tail Rotor Components

Loss of any tail rotor component will result in a forward CG shift. Other than additional nose down pitching, this situation would be quite similar to complete loss of tail rotor thrust as discussed above.

### 3.5.3 Tail Rotor Fixed Pitch Failures

Indications:

Tail rotor pitch change control failures are characterized either by a lack of directional response when a pedal is pushed or by locked pedals. If pedals can not be moved with a moderate amount of force, do not attempt to apply a maximum effort since a more serious malfunction could result.

### 3.5.4 Fixed Pitch Failure at a Hover

Procedure:

Do not close throttle unless a severe right yaw occurs. If pedals lock in any position at a hover, landing from a hover can be accomplished with greater safety under power controlled flight rather than by closing throttle and entering autorotation.

### 3.5.5 Fixed Pitch Failure in Flight

If tail rotor fixed pitch failure occurs during climb (left pedal applied), cruise (approximately neutral pedals), and descent (right pedal applied), a descent and landing can be effected safely by use of power and throttle changes.

• COPYRIGHT © 2007 BY EAGLE COPTERS MAINTENANCE LTD •

This document is private and confidential and is supplied on the express condition that it is not to be used for any purpose or copied or communicated to any other person without written permission from Eagle Copters Maintenance Ltd.

**Procedures:**

If helicopter is in a trimmed condition when malfunction is discovered, engine power and airspeed should be noted and the helicopter flown to a suitable landing area.

Combinations of ENG TORQUE, ROTOR RPM ( $N_R$ ), and AIRSPEED will correct or aggravate yaw attitude and these should be adjusted as required to control yaw during landing.

**Right Pedal Locked Forward of Neutral:**

Power should be reduced and ENG RPM ( $N_2$ ) maintained within green arc. This will help streamline helicopter in flight. Right turns are easier than left turns. AIRSPEED should be maintained at or above 60 KIAS.

Execute a normal to steep approach adjusting power as necessary to minimize or prevent right yaw. Maintain ENG RPM ( $N_2$ ) and an AIRSPEED of 60 KIAS during initial part of approach.

At 60 to 75 feet AGL and when landing area can be made, start a slow deceleration to arrive at intended landing point with AIRSPEED at about 25 KIAS.

At 2 to 5 feet AGL, slowly reduce throttle to overcome yaw effect and allow helicopter to settle. When aligned with landing area, allow helicopter to touchdown.

After ground contact, use collective and throttle as necessary to maintain alignment with landing strip, and to minimize forward speed. If helicopter starts to turn, move cyclic as necessary to follow turn until helicopter comes to a complete stop.

**Left Pedal Locked Forward of Neutral:**

Reduce power and maintain ENG RPM ( $N_2$ ) within the green arc. Normal turns can be safely made under these conditions, although the helicopter nose may be displaced to left.

• COPYRIGHT © 2007 BY EAGLE COPTERS MAINTENANCE LTD •

This document is private and confidential and is supplied on the express condition that it is not to be used for any purpose or copied or communicated to any other person without written permission from Eagle Copters Maintenance Ltd.

On final approach, begin a slow deceleration so as to arrive at a point about four to five feet above intended touchdown area as effective translational lift is lost.

Apply collective to stop rate of descent and forward speed, and to align helicopter with intended landing path. Allow helicopter to touchdown at near zero ground speed, maintaining alignment with throttle.

Pedals Locked in Neutral:

Reduce power and maintain ENG RPM (N<sub>2</sub>) within green arc. Normal turns can be safely made under these conditions.

Execute a normal to shallow approach, holding AIRSPEED at 60 KIAS during initial part of approach. Adjust power as necessary to minimize or prevent right yaw.

At 50 to 75 feet AGL and when landing area can be made, start a deceleration to arrive at intended landing point with AIRSPEED at 25 KIAS.

At 2 to 5 feet AGL, use throttle slowly as necessary to maintain alignment with landing area and to control yaw; do not allow helicopter to settle until alignment is assured, then touchdown.

After ground contact, use collective and throttle as necessary to minimize forward speed and to maintain alignment. Move cyclic as necessary to follow turn until helicopter has come to a complete stop.

### 3.5.6 Loss of Pitch Change Control Linkage

Indications:

In this type of failure, pitch change mechanism is broken at some point and the tail rotor will assume a blade angle determined by aerodynamic and counterbalance forces.

Procedures:

Corrective action procedures are described in FIXED PITCH FAILURES above. The specific procedure to be used depends on yaw change experienced.

• COPYRIGHT © 2007 BY EAGLE COPTERS MAINTENANCE LTD •

This document is private and confidential and is supplied on the express condition that it is not to be used for any purpose or copied or communicated to any other person without written permission from Eagle Copters Maintenance Ltd.

## 3.6 Hydraulic System

The helicopter has two hydraulic powered flight control systems (1 and 2). Both systems supply power to collective and cyclic, but tail rotor is powered only by system 1.

If system pressure or temperature exceeds limits, affected system should be turned off. Continued flight and normal maneuvers can be accomplished on remaining system. Land as soon as practical. If system no. 1 fails and is turned off, tail rotor control forces will increase but no change in limitations result.

Indications:

1. #1 or #2 HYDR SYST caution light is illuminated.  
*If SYS 1 has failed:*
2. Pedal forces will increase

Procedure:

1. HYD SYS 1 and 2 switches – Verify ON
2. Affected Hydraulic CONT circuit breaker – OUT, if hydraulics not restored, push IN.
3. Affected HYD SYS switch – OFF
4. Airspeed – As desired
5. Land as soon as practical.

## 3.7 Electrical System

### 3.7.1 Generator Failure

Indications:

1. DC GENERATOR caution light illuminated.
2. Lighting and avionics on nonessential busses inoperative.

Procedure:

• COPYRIGHT © 2007 BY EAGLE COPTERS MAINTENANCE LTD •

This document is private and confidential and is supplied on the express condition that it is not to be used for any purpose or copied or communicated to any other person without written permission from Eagle Copters Maintenance Ltd.

Revision: **M**

Date: 2026-04-13

TCCA Approved

1. GEN FIELD and GEN RESET circuit breakers – Check IN
2. GENERATOR switch – RESET, then ON.

*If DC GENERATOR caution light remains on:*

3. GEN switch – OFF
4. All unnecessary equipment OFF.

#### Note

*The Non-Essential Buss can be restored after eliminating undesired circuit loads by moving the bus selector switch to MANUAL.*

5. Land as soon as practical.

## 3.8 Fuel System

### 3.8.1 Fuel boost pump failure

Indications:

1. LH or RH FUEL BOOST caution light illuminated.
2. A decrease in fuel pressure

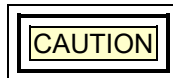

IF EITHER BOOST PUMP FAILS, FUEL EXHAUSTION COULD OCCUR AT 60 POUNDS INDICATED ON FUEL QUANTITY GAGE.

Procedure:

1. Altitude – If practical descend below 4600 feet Hp
2. Land as soon as practical.

• COPYRIGHT © 2007 BY EAGLE COPTERS MAINTENANCE LTD •

This document is private and confidential and is supplied on the express condition that it is not to be used for any purpose or copied or communicated to any other person without written permission from Eagle Copters Maintenance Ltd.

## 3.8.2 Fuel Filter Partially Blocked

Indications:

1. FUEL FILTER caution light illuminated.

Procedure:

1. Land as soon as practical.

## 3.8.3 Fuel Quantity Indication Malfunctions

Indication:

1. Fuel quantity indications freezes in place (possible power failure to the fuel quantity indicator system).

Procedure:

1. FUEL QTY circuit breaker – Recycle

Note

*A failure in the fuel quantity indicating system will have no effect on fuel low caution light, fuel interconnect, fuel crossfeed, fuel boost or fuel valve and indications.*

## 3.9 Communications System

### 3.9.1 Intercom Failure

Indications:

1. Weak or no reception in headsets

Procedures:

1. Check headset connection.
2. Verify volume and ICS controls set properly
3. Cycle ICS circuit breaker out and in.

• COPYRIGHT © 2007 BY EAGLE COPTERS MAINTENANCE LTD •

This document is private and confidential and is supplied on the express condition that it is not to be used for any purpose or copied or communicated to any other person without written permission from Eagle Copters Maintenance Ltd.

## 3.10 Cabin Heater

### Note

*A malfunction in the bleed air heater controls may or may not cause heater to become inoperative.*

### 3.10.1 Heater Air

#### Indications:

1. HEATER AIR LINE caution light illuminates.
2. Heated airflow does not shut off when thermostat knob is turned to full cold position.
3. Heater Valve does not close when Heater selected to OFF.
4. Heater Valve does not open when Heater selected to ON.

#### Procedure:

1. HEATER switch – OFF immediately.
2. CABIN HTR circuit breaker – Check; if out, do not reset. If not out, PULL breaker. Select thermostat knob to FULL COLD.
3. Check prior to next flight.

• COPYRIGHT © 2007 BY EAGLE COPTERS MAINTENANCE LTD •

This document is private and confidential and is supplied on the express condition that it is not to be used for any purpose or copied or communicated to any other person without written permission from Eagle Copters Maintenance Ltd.

### 3.10.2 Heater Overheat

Indications:

1. HEATER O/HEAT caution light illuminates.
2. High temperature detected in heater ducting.

Procedure:

1. HEATER switch – OFF immediately.
2. CABIN HTR circuit breaker – Check; if out, do not reset. If not out, pull breaker
3. Check prior to next flight.

### 3.11 *Warning and Caution Lights Messages*

Red warning lights/messages, fault conditions and corrective actions are presented in Table 3-1

Amber caution lights/messages, fault conditions and corrective actions are presented in Table 3-2.

• COPYRIGHT © 2007 BY EAGLE COPTERS MAINTENANCE LTD •

This document is private and confidential and is supplied on the express condition that it is not to be used for any purpose or copied or communicated to any other person without written permission from Eagle Copters Maintenance Ltd.

Table 3-1 Warning Segments (Red)

| Segment Indication                              | Fault Condition   | Corrective Action   |
|---|---|---|
| CARGO FIRE                                      | Smoke or fire in cargo compartment  | <ol style="list-style-type: none"> <li>1. Reduce power.</li> <li>2. Land as soon as possible.</li> </ol>  |
| ENGINE RPM                                      | In the event of an engine failure or gas producer RPM (N <sub>1</sub> ) abnormally low, the red ENGINE RPM light will illuminate and audio will signal. | <ol style="list-style-type: none"> <li>1. Immediately execute an autorotative descent.</li> </ol>   |
| ENG OIL PRESS                                   | Engine oil pressure below limit.  | <ol style="list-style-type: none"> <li>1. Check oil pressure gauge.</li> <li>2. Land as soon as possible.</li> </ol>  |
| FIRE 1 PULL (S/Ns 30817, 30687, and 30599 Only) | Fire indication in engine compartment   | <ol style="list-style-type: none"> <li>1. Emergency descent – If possible</li> <li>2. FIRE 1 PULL handle – PULL</li> <li>3. EXTING switch – Extinguish</li> <li>4. Land Immediately</li> <li>5. Throttle – Close.</li> <li>6. FUEL VALVE switch - OFF</li> <li>7. BAT switch – OFF</li> <li>8. Helicopter – Exit</li> </ol> |

• COPYRIGHT © 2007 BY EAGLE COPTERS MAINTENANCE LTD •

This document is private and confidential and is supplied on the express condition that it is not to be used for any purpose or copied or communicated to any other person without written permission from Eagle Copters Maintenance Ltd.

Revision: **M**

Date: 2026-04-13

TCCA Approved

Table 3-1 Warning Segments (Red)

|  |  |   |
|--|--|---|
| <p>ENGINE FIRE<br/>All S/Ns<br/><b><u>EXCEPT</u></b><br/>30817, 30687,<br/>and 30599</p> | <p>Fire indication in engine compartment</p> | <ol style="list-style-type: none"> <li>1. Emergency descent – If possible</li> <li>2. ENGINE FIRE switch-light – Lift cover, PRESS to arm (Either switch)</li> <li>3. FIRE EXTING switch-light – Lift cover, PRESS (Either switch)</li> <li>4. Land Immediately</li> <li>5. Throttle – Close.</li> <li>6. FUEL VALVE switch - OFF</li> <li>7. BAT switch – OFF</li> <li>8. Helicopter – Exit</li> </ol> |
|--|--|---|

|                                    |   |  |
|------------------------------------|---|--|
| <p>ROTOR BK<br/>(if installed)</p> | <p>Rotor brake linings not retracted.</p> | <ol style="list-style-type: none"> <li>1. Check rotor brake handle in detent. If light remains illuminated, land as soon as possible.</li> </ol> |
|------------------------------------|---|--|

|                           |   |   |
|---------------------------|---|---|
| <p>XMSN OIL<br/>PRESS</p> | <p>Transmission oil pressure below limit.</p> | <ol style="list-style-type: none"> <li>1. Reduce power. Land immediately</li> </ol> |
|---------------------------|---|---|

|                          |   |  |
|--------------------------|---|--|
| <p>XMSN OIL<br/>TEMP</p> | <p>Transmission oil temperature above limit</p> | <ol style="list-style-type: none"> <li>1. Reduce power. Check XMSN oil temperature. If not within limits, land as soon as possible.</li> </ol> |
|--------------------------|---|--|

• COPYRIGHT © 2007 BY EAGLE COPTERS MAINTENANCE LTD •

This document is private and confidential and is supplied on the express condition that it is not to be used for any purpose or copied or communicated to any other person without written permission from Eagle Copters Maintenance Ltd.

Table 3-2 Caution Segments (Amber)

| Segment Indication | Fault Condition                         | Corrective Action  |
|--------------------|---|--|
| Blank or spare     | Unknown                                 | 1. Land as soon as possible.   |
| CARGO DOOR         | Cargo door not properly secured.        | 1. Land as soon as practical.  |
| CAUTION PANEL      | Caution panel inoperative               | 1. MASTER CAUTION circuit breaker – Check IN.<br>2. Helicopter system instruments – Monitor closely<br>3. Land as soon as practical. |
| CHIP – ENGINE      | Metal detected in engine oil.           | 1. Reduce power.<br>2. Land as soon as possible.   |
| CHIP – XMSN        | Metal detected in transmission.         | 1. Land as soon as practical.  |
| CHIP – 42° GB      | Metal particles in intermediate gearbox | 1. Land as soon as practical.  |
| CHIP – 90° GB      | Metal particles in tail rotor gearbox   | 1. Land as soon as practical.  |

• COPYRIGHT © 2007 BY EAGLE COPTERS MAINTENANCE LTD •

This document is private and confidential and is supplied on the express condition that it is not to be used for any purpose or copied or communicated to any other person without written permission from Eagle Copters Maintenance Ltd.

Table 3-2 Caution Segments (Amber)

| Segment Indication | Fault Condition                                | Corrective Action   |
|--------------------|--|---|
| DC GENERATOR       | Generator has failed or circuit open.          | <ol style="list-style-type: none"> <li>1. GEN FIELD and RESET circuit breaker – Check in.</li> <li>2. GENERATOR switch – RESET position, then ON.</li> </ol> <p><i>If generator fails to reset</i></p> <ol style="list-style-type: none"> <li>3. GEN switch – OFF.</li> <li>4. BAT – Check ON.</li> <li>5. All unnecessary electrical equipment – OFF.</li> <li>6. If possible – descend below 4600 feet pressure altitude.</li> <li>7. Land as soon as practical.</li> </ol> |
| ENGINE DE-ICE ON   | ENG DE-ICE switch ON                           | <ol style="list-style-type: none"> <li>1. ENG DE-ICE switch – Position as desired.</li> </ol>   |
| ENG FUEL PUMP      | Failure of either element of dual element pump | <ol style="list-style-type: none"> <li>1. Land as soon as possible.</li> </ol>  |
| ENG ICE DET        | Engine ice detector system malfunctioned       | <ol style="list-style-type: none"> <li>1. Icing conditions – Avoid</li> </ol>   |
| ENG ICING          | Icing conditions present                       | <ol style="list-style-type: none"> <li>1. ENG DE-ICE switch – ON</li> <li>2. Land as soon as practical</li> </ol>   |

• COPYRIGHT © 2007 BY EAGLE COPTERS MAINTENANCE LTD •

This document is private and confidential and is supplied on the express condition that it is not to be used for any purpose or copied or communicated to any other person without written permission from Eagle Copters Maintenance Ltd.

Revision: **M**

Date: 2026-04-13

TCCA Approved

Table 3-2 Caution Segments (Amber)

| Segment Indication | Fault Condition   | Corrective Action   |
|--------------------|---|---|
| ENG OIL FILTER     | Filter partially clogged  | 1. Continue flight. Correct before next flight.   |
| EXTERNAL PWR       | External power door open.   | 1. Check external power disconnected.<br>2. Check external door closed.   |
| FUEL FILTER        | Filter partially clogged  | 1. Continue flight. Correct before next flight.   |
| FUEL VALVE         | Fuel valve not in selected position or properly seated or circuit breaker open. | 1. FUEL VALVE circuit breaker - IN.<br>2. Land as soon as practical.<br>IF on ground: FUEL VALVE switch – OFF, then ON. |
| GOV MANUAL         | Governor in manual mode.  | 1. N <sub>1</sub> must be controlled with throttle  |

• COPYRIGHT © 2007 BY EAGLE COPTERS MAINTENANCE LTD •

This document is private and confidential and is supplied on the express condition that it is not to be used for any purpose or copied or communicated to any other person without written permission from Eagle Copters Maintenance Ltd.

Table 3-2 Caution Segments (Amber)

| Segment Indication                 | Fault Condition  | Corrective Action  |
|------------------------------------|--|--|
| HEATER AIR LINE                    | Heated airflow does not shut off when thermostat knob is turned to full cold position. | <ol style="list-style-type: none"> <li>1. HEATER switch – OFF immediately.</li> <li>2. CABIN HTR circuit breaker – Check; if out, do not reset. If not out, PULL breaker. Select thermostat knob to FULL COLD.</li> <li>3. Continue flight. Correct before next flight.</li> </ol> |
| HEATER O/HEAT                      | High temperature detected in heater ducting.   | <ol style="list-style-type: none"> <li>1. HEATER switch – OFF immediately.</li> <li>2. CABIN HTR circuit breaker – Check; if out, do not reset. If not out – Pull breaker.</li> <li>3. Continue flight. Correct before next flight.</li> </ol>                                     |
| #1 HYDR SYST<br>or<br>#2 HYDR SYST | Hydraulic pressure below limit or temperature above limit.                             | <ol style="list-style-type: none"> <li>1. Verify fault by reading affected gauge.</li> <li>2. Turn off affected system.</li> <li>3. Land as soon as practical.</li> </ol>  |

• COPYRIGHT © 2007 BY EAGLE COPTERS MAINTENANCE LTD •

This document is private and confidential and is supplied on the express condition that it is not to be used for any purpose or copied or communicated to any other person without written permission from Eagle Copters Maintenance Ltd.

Revision: **M**

Date: 2026-04-13

TCCA Approved

Table 3-2 Caution Segments (Amber)

| Segment Indication   | Fault Condition  | Corrective Action   |
|--|--|---|
| #1 INVERTER<br>or<br>#2 INVERTER<br>(S/Ns 30817,<br>30687, and 30599<br>Only)              | Applicable inverter<br>has failed  | <ol style="list-style-type: none"> <li>1. Verify other Inverter is powering AC busses by reading Voltmeters.</li> <li>2. Turn off inoperative Inverter.</li> <li>3. Continue flight. Correct before next flight.</li> </ol> |
| #1 INVERTER<br>or<br>#2 INVERTER<br>(All S/Ns <b>EXCEPT</b><br>30817, 30687, and<br>30599) | Applicable inverter<br>has failed  | <ol style="list-style-type: none"> <li>1. Turn off inoperative Inverter.</li> <li>2. Continue flight. Correct before next flight.</li> </ol>  |
| LH FUEL BOOST<br>or<br>RH FUEL BOOST   | Indicated boost pump<br>on with no fuel<br>pressure or boost<br>pump failure has<br>occurred on indicated<br>pump. | <ol style="list-style-type: none"> <li>1. If practical, descend below 4600 feet H<sub>P</sub> to prevent possible fuel starvation in the event remaining boost pump fails.</li> <li>2. Land as soon as practical</li> </ol> |
| LH or RH FUEL<br>LOW   | Fuel quantity low.   | <ol style="list-style-type: none"> <li>1. Verify fuel quantity.</li> <li>2. Land as soon as practical.</li> </ol>   |

• COPYRIGHT © 2007 BY EAGLE COPTERS MAINTENANCE LTD •

This document is private and confidential and is supplied on the express condition that it is not to be used for any purpose or copied or communicated to any other person without written permission from Eagle Copters Maintenance Ltd.

Revision: **M**

Date: 2026-04-13

TCCA Approved

Table 3-2 Caution Segments (Amber)

| Segment Indication | Fault Condition   | Corrective Action   |
|--------------------|---|---|
| PASS DOOR          | Cabin door open.  | <ol style="list-style-type: none"> <li>1. Visually check cabin doors.</li> <li>2. Decrease airspeed as required.</li> <li>3. Land as soon as possible.</li> </ol>         |
| ROTOR RPM          | Rotor RPM at or below 97% ( <u>with</u> audio tone)   | <ol style="list-style-type: none"> <li>1. Adjust rotor RPM within limits</li> </ol>   |
|                    | OR  |   |
| BATTERY            | Rotor RPM at or above 103% ( <u>No</u> audio tone)<br>Battery relay open or both battery switches in same position. | <ol style="list-style-type: none"> <li>1. Position BATTERY switch to OFF. Position BATTERY switch to ON. If light does not extinguish, position switch to OFF.</li> </ol> |

• COPYRIGHT © 2007 BY EAGLE COPTERS MAINTENANCE LTD •

This document is private and confidential and is supplied on the express condition that it is not to be used for any purpose or copied or communicated to any other person without written permission from Eagle Copters Maintenance Ltd.

# Section 4

## Performance Data

### Table of Contents

|       |   |      |
|-------|---|------|
| 4.1   | Engine Operation Check Charts .....             | 4-3  |
| 4.2   | Maximum Power (Torquemeter Pressure) Check..... | 4-4  |
| 4.3   | Power Assurance Checks .....                    | 4-7  |
| 4.3.1 | Sample Problem (T53-17A Engine): .....          | 4-7  |
| 4.3.2 | Sample Problem (T53-17B/BCV Engine):.....       | 4-9  |
| 4.4   | Hover Ceiling Charts .....                      | 4-11 |
| 4.5   | Takeoff Distance .....                          | 4-11 |
| 4.6   | Rate of Climb – Maximum.....                    | 4-11 |
| 4.7   | Landing Distance.....                           | 4-12 |
| 4.8   | Height Velocity .....                           | 4-12 |
| 4.9   | Operation vs Allowable Wind .....               | 4-13 |
| 4.10  | Airspeed System Calibration.....                | 4-14 |

### List of Figures

|            |   |      |
|------------|---|------|
| Figure 4-1 | – T53-17A/B/BCV – Maximum Power Check Chart .....                 | 4-6  |
| Figure 4-2 | – T53-17A – Power Assurance Check .....                           | 4-8  |
| Figure 4-3 | – T53-17B/BCV – Power Assurance Chart – Ground/Hover....          | 4-10 |
| Figure 4-4 | – Operation vs Allowable Wind Above 10,500 Lbs .....              | 4-13 |
| Figure 4-5 | – Operation vs Allowable Wind 10,500 Lbs and Below.....           | 4-14 |
| Figure 4-6 | – Hover Ceiling (without Particle Separator) (Sheet 1 of 8) ..... | 4-15 |
| Figure 4-6 | – Hover Ceiling (without Particle Separator) (Sheet 2 of 8) ..... | 4-16 |
| Figure 4-6 | – Hover Ceiling (without Particle Separator) (Sheet 3 of 8) ..... | 4-17 |
| Figure 4-6 | – Hover Ceiling (without Particle Separator) (Sheet 4 of 8) ..... | 4-18 |
| Figure 4-6 | – Hover Ceiling (without Particle Separator) (Sheet 5 of 8) ..... | 4-19 |
| Figure 4-6 | – Hover Ceiling (without Particle Separator) (Sheet 6 of 8) ..... | 4-20 |
| Figure 4-6 | – Hover Ceiling (without Particle Separator) (Sheet 7 of 8) ..... | 4-21 |
| Figure 4-6 | – Hover Ceiling (without Particle Separator) (Sheet 8 of 8) ..... | 4-22 |
| Figure 4-7 | – Takeoff Distance (Sheet 1 of 12).....                           | 4-23 |

• COPYRIGHT © 2007 BY EAGLE COPTERS MAINTENANCE LTD •

This document is private and confidential and is supplied on the express condition that it is not to be used for any purpose or copied or communicated to any other person without written permission from Eagle Copters Maintenance Ltd.



Figure 4-7 – Takeoff Distance (Sheet 2 of 12)..... 4-24

Figure 4-7 – Takeoff Distance (Sheet 3 of 12)..... 4-25

Figure 4-7 – Takeoff Distance (Sheet 4 of 12)..... 4-26

Figure 4-7 – Takeoff Distance (Sheet 5 of 12)..... 4-27

Figure 4-7 – Takeoff Distance (Sheet 6 of 12)..... 4-28

Figure 4-7 – Takeoff Distance (Sheet 7 of 12)..... 4-29

Figure 4-7 – Takeoff Distance (Sheet 8 of 12)..... 4-30

Figure 4-7 – Takeoff Distance (Sheet 9 of 12)..... 4-31

Figure 4-7 – Takeoff Distance (Sheet 10 of 12)..... 4-32

Figure 4-7 – Takeoff Distance (Sheet 11 of 12)..... 4-33

Figure 4-7 – Takeoff Distance (Sheet 12 of 12)..... 4-34

Figure 4-8 – Rate of Climb – Maximum (Sheet 1 of 2) ..... 4-35

Figure 4-8 – Rate of Climb – Maximum (Sheet 2 of 2) ..... 4-36

Figure 4-9 – Landing Distance (Sheet 1 of 6) ..... 4-37

Figure 4-9 – Landing Distance (Sheet 2 of 6) ..... 4-38

Figure 4-9 – Landing Distance (Sheet 3 of 6) ..... 4-39

Figure 4-9 – Landing Distance (Sheet 4 of 6) ..... 4-40

Figure 4-9 – Landing Distance (Sheet 5 of 6) ..... 4-41

Figure 4-9 – Landing Distance (Sheet 6 of 6) ..... 4-42

Figure 4-10 – Pilot Airspeed System Calibration ..... 4-43

Figure 4-11 – Copilot Airspeed System Calibration ..... 4-44

Figure 4-12 – Glide Distance ..... 4-45

Figure 4-13 – Density Altitude – Pressure Altitude ..... 4-46

Figure 4-14 – Height Velocity Chart..... 4-47

• COPYRIGHT © 2007 BY EAGLE COPTERS MAINTENANCE LTD •

This document is private and confidential and is supplied on the express condition that it is not to be used for any purpose or copied or communicated to any other person without written permission from Eagle Copters Maintenance Ltd.

## Section 4

### *Performance Data*

#### **4.1 Engine Operation Check Charts**

A Maximum Power Check chart (Figure 4-1) is provided to aid the pilot in determining engine condition based on the relation of altitude/temperature and maximum power (maximum torque/pressure).

If this check is satisfactory, published Flight Manual performance can be equaled or bettered depending on how much the installed engine is better than the theoretical “specification engine” on which the published performance is based. Check can easily be made by using normal cockpit instruments, and the methods described herein.

As an alternative to the Maximum Power Check chart (Figure 4-1), Power Assurance Check charts (Figure 4-2 and 4-3) are provided to determine if the engine can produce installed power required to meet the published performance data. Figure 4-2 applies to the T5317A engine and Figure 4-3 applies to the T5317B/BCV engine. The power assurance check shall be performed at a hover.

A power assurance check should be performed daily. Additional checks should be made if unusual operating conditions or indications arise.

If engine does not meet requirements of power assurance check, published performance may not be achievable. The cause should be determined as soon as practical. Refer to Engine Maintenance Manual.

• COPYRIGHT © 2007 BY EAGLE COPTERS MAINTENANCE LTD •

This document is private and confidential and is supplied on the express condition that it is not to be used for any purpose or copied or communicated to any other person without written permission from Eagle Copters Maintenance Ltd.

## 4.2 Maximum Power (Torquemeter Pressure) Check

The purpose of this check is to determine whether or not the installed engine will deliver torquemeter pressure (power) equal to or greater than a minimum specification engine. Since the minimum specification engine is capable of delivering 1500 horsepower, and the engine as installed in the helicopter is de-rated to 1290 horsepower, care must be taken not to exceed the power limitation (55.7 PSI (100%) torquemeter pressure). This “full throttle” power check, in order to be conclusive, must be made at conditions of altitude and temperature at which full throttle will produce no more than 55.7 PSI (100%) torquemeter pressure. This check should be accomplished in the following manner:

De-ice OFF, Cabin heat OFF

Initiate a climb at best climb speed and 100 percent N<sub>2</sub>

Maintain climb and increase collective (not to exceed 55.7 PSI (100%) of torque) until the N<sub>2</sub> speed drops to 98 percent with the governor RPM switch “Beeped” to full increase.

Read and record the following

Example

|                                      |                  |
|--------------------------------------|------------------|
| Pressure altitude                    | 6000 ft          |
| Ambient air temperature              | 30°C             |
| Torquemeter pressure                 | 53.2 PSI (95.5%) |
| Gas producer speed (N <sub>1</sub> ) | 96.6%            |

Enter chart (Figure 4-1) at pressure altitude (Point A), proceed horizontally to ambient air temperature (Point B), and then proceed vertically down and read chart torquemeter pressure (Point C). Example: 52.0 PSI (93.4%)

Since the observed maximum torquemeter pressure of the example (53.2 PSI (95.5%)) is no less than the chart maximum torquemeter pressure (52.0 PSI (93.4%)) the maximum torquemeter pressure available is satisfactory.

• COPYRIGHT © 2007 BY EAGLE COPTERS MAINTENANCE LTD •

This document is private and confidential and is supplied on the express condition that it is not to be used for any purpose or copied or communicated to any other person without written permission from Eagle Copters Maintenance Ltd.



The recorded  $N_1$  RPM shall be plus or minus 0.5 percent of the placarded Maximum Gas Producer Speed for Takeoff Power. (This is  $N_1$  topping.)

If this check is satisfactory, it can be concluded that the installed engine is at least as good as a minimum specification engine and that full power can be obtained. If this check is not satisfactory, there is reason to believe that the engine has deteriorated to the extent that published performance may not be obtained. If this occurs, the cause of the deterioration should be determined.

• COPYRIGHT © 2007 BY EAGLE COPTERS MAINTENANCE LTD •

This document is private and confidential and is supplied on the express condition that it is not to be used for any purpose or copied or communicated to any other person without written permission from Eagle Copters Maintenance Ltd.

TCCA Approved

Revision: **M**

Date: 2026-04-13

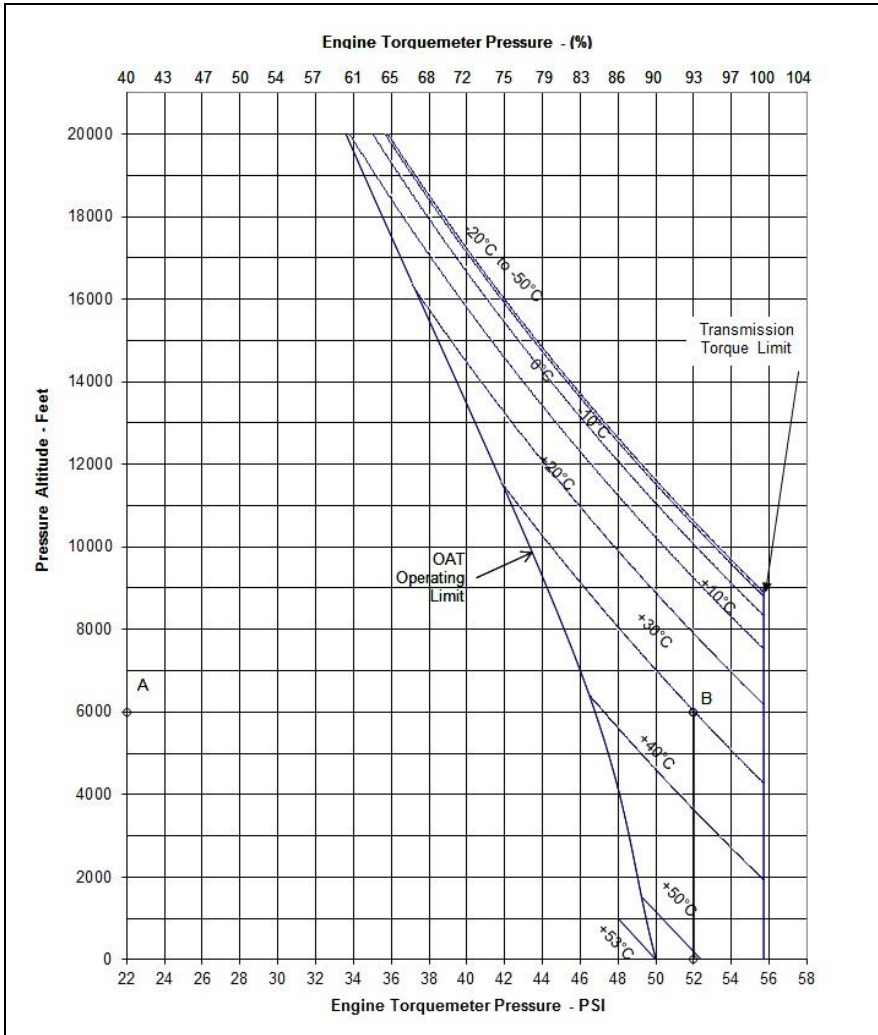

Figure 4-1 – T53-17A/B/BCV – Maximum Power Check Chart

• COPYRIGHT © 2007 BY EAGLE COPTERS MAINTENANCE LTD •

This document is private and confidential and is supplied on the express condition that it is not to be used for any purpose or copied or communicated to any other person without written permission from Eagle Copters Maintenance Ltd.

Revision: **M**

Date: 2026-04-13

TCCA Approved

## 4.3 Power Assurance Checks

### 4.3.1 Sample Problem (T53-17A Engine):

Stabilize the helicopter headed into the wind at a hover with De-ice OFF and cabin heat OFF; the following is an example:

|   |                    |
|---|--------------------|
| Pressure altitude                           | Example<br>4000 ft |
| Selected torque meter pressure              | 35 PSI (63%)       |
| Engine RPM (N <sub>2</sub> ) adjust to      | 100%               |
| <i>Read and record the following values</i> |                    |
| Ambient air temperature                     | 20°C               |
| Exhaust gas temperature                     | 575°C              |

Enter chart (Figure 4-2) at OAT (Point A). Proceed vertically to pressure altitude (Point B). Proceed horizontally to torque meter pressure (Point C). Proceed vertically to OAT (Point D). Proceed horizontally to EGT (Point E)

Example:

Figure 4-2 Minimum Specification EGT – 585°C

Since the actual exhaust gas temperature (575°C) is not greater than the charted exhaust gas temperature (585°C), the relation between power and exhaust gas temperature is satisfactory.

• COPYRIGHT © 2007 BY EAGLE COPTERS MAINTENANCE LTD •

This document is private and confidential and is supplied on the express condition that it is not to be used for any purpose or copied or communicated to any other person without written permission from Eagle Copters Maintenance Ltd.

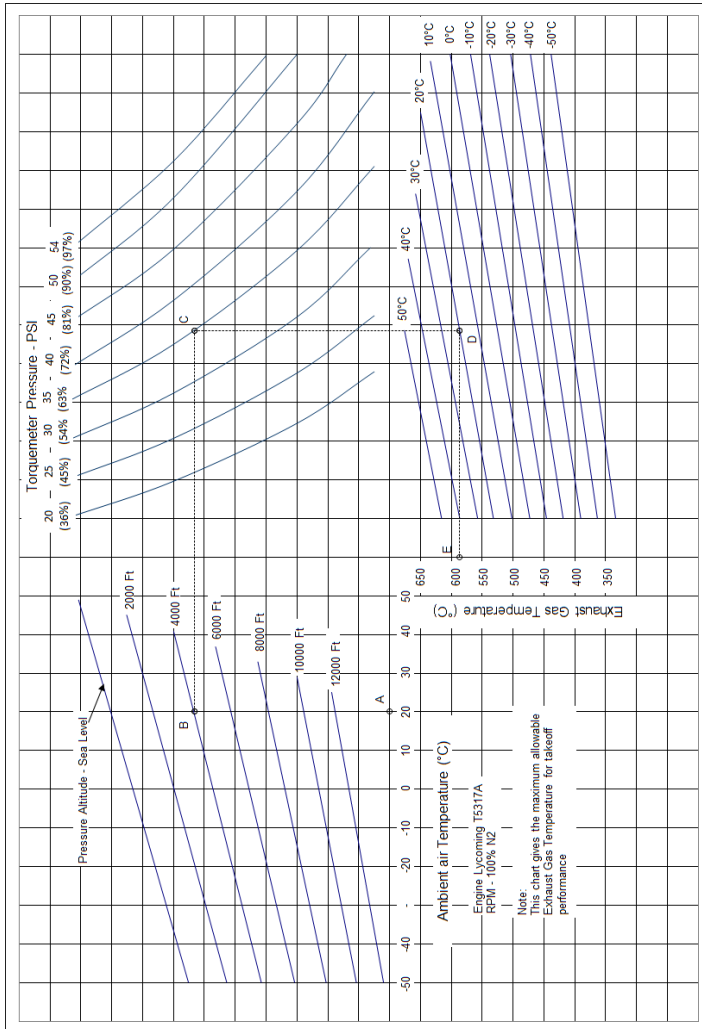

Takeoff Power  
Figure 4-2 – T53-17A – Power Assurance Check

• COPYRIGHT © 2007 BY EAGLE COPTERS MAINTENANCE LTD •

This document is private and confidential and is supplied on the express condition that it is not to be used for any purpose or copied or communicated to any other person without written permission from Eagle Copters Maintenance Ltd.

### 4.3.2 Sample Problem (T53-17B/BCV Engine):

Stabilize the helicopter headed into the wind at a hover with De-ice OFF and cabin heat OFF; the following is an example:

|   | Example        |
|---|----------------|
| Pressure altitude                           | 1000 ft        |
| Selected torquemeter pressure               | 43.5 PSI (78%) |
| Engine RPM (N <sub>2</sub> ) adjust to      | 100%           |
| <i>Read and record the following values</i> |                |
| Ambient air temperature                     | 0°C            |
| Measured gas temperature                    | 680°C          |

Enter chart (Figure 4.3) at torque value (Point A). Proceed horizontally to pressure altitude (Point B). Proceed vertically to OAT value (Point C), then proceed horizontally to minimum specification MGT (Point D).

Example:

Figure 4-3 Minimum Specification MGT – 700°C

Since the actual measured gas temperature (680°C) is not greater than the charted measured gas temperature (700°C), the relation between power and measured gas temperature is satisfactory.

• COPYRIGHT © 2007 BY EAGLE COPTERS MAINTENANCE LTD •

This document is private and confidential and is supplied on the express condition that it is not to be used for any purpose or copied or communicated to any other person without written permission from Eagle Copters Maintenance Ltd.

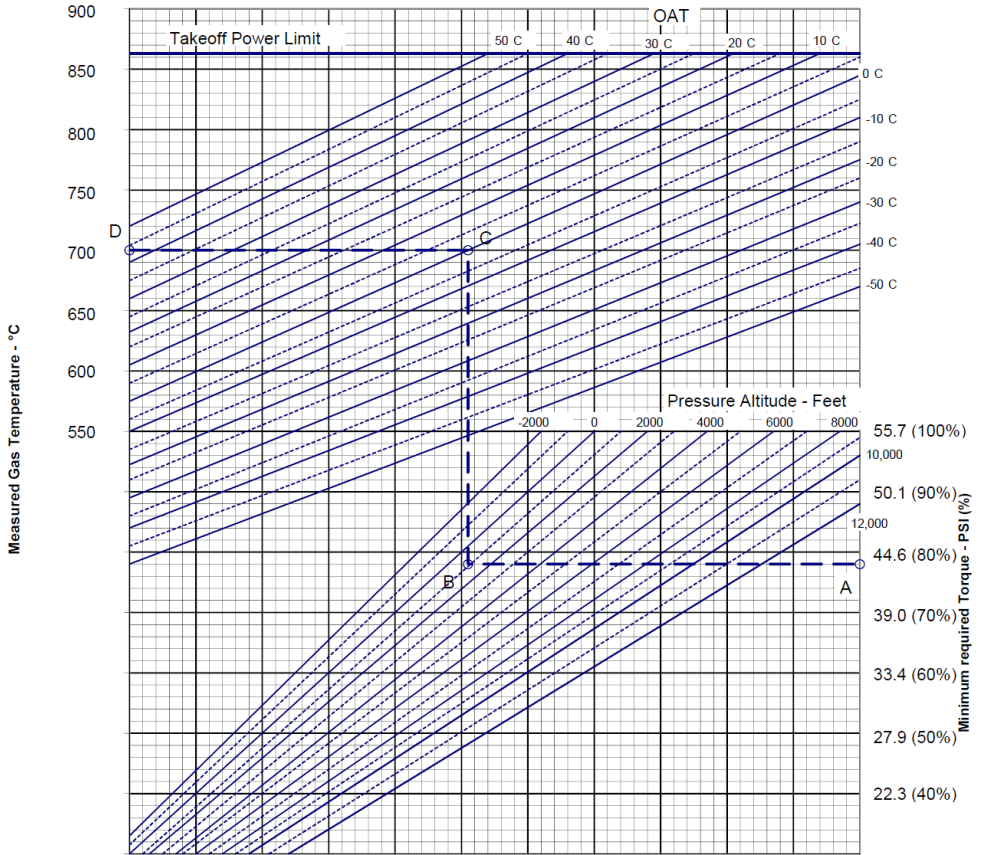

Figure 4-3 – T53-17B/BCV – Power Assurance Chart – Ground/Hover

• COPYRIGHT © 2007 BY EAGLE COPTERS MAINTENANCE LTD •

This document is private and confidential and is supplied on the express condition that it is not to be used for any purpose or copied or communicated to any other person without written permission from Eagle Copters Maintenance Ltd.

Revision: **M**

Date: 2026-04-13

TCCA Approved

## 4.4 Hover Ceiling Charts

The Hover Ceiling charts (Figure 4-6, Sheets 1–8) present hover performance IGE and OGE (allowable gross weight) for conditions of pressure altitude and outside air temperature (OAT). For actual gross weight limitations during takeoff and landing, refer to Density Altitude – Gross Weight Limit for Takeoff and Landing, Section 1. The 204-704-037-003 particle separator kit is not approved as part of this modification.

## 4.5 Takeoff Distance

The Takeoff Distance Charts (Figure 4-7, Sheets 1-12) provide takeoff distances required to clear a 50 foot obstacle in a zero wind condition, using a takeoff flight path which will avoid the critical areas of the Height-Velocity Chart (Figure 4-14) for Smooth, Level, Firm Surfaces. Takeoff is initiated from a 4 foot hover.

## 4.6 Rate of Climb – Maximum

4.6.1 The Rate of Climb – Maximum charts predict the approximate rate of climb at all allowable density altitudes for the Eagle Single in two different configurations:

4.6.1.1 The first configuration, all bleed air systems are off, maintains 55.7 PSI (100%) engine torque until the altitude or OAT increases the MGT to 863°C takeoff limit or the EGT takeoff limit found on the OAT vs EGT limits placard. If the climb is continued the engine torque will decrease.

Note

*Takeoff power is limited to 5 minutes.*

4.6.1.2 The second configuration, engine de-ice on, maintains maximum continuous power which is limited by engine torque (49 PSI (88%)) at low altitude. As altitude or OAT increases the flight crew will be limited to the

• COPYRIGHT © 2007 BY EAGLE COPTERS MAINTENANCE LTD •

This document is private and confidential and is supplied on the express condition that it is not to be used for any purpose or copied or communicated to any other person without written permission from Eagle Copters Maintenance Ltd.

maximum continuous MGT or 820°C or the maximum continuous EGT which is found on the OAT vs EGT limits placard.

4.6.1.3 To determine rate of climb at a particular OAT and pressure altitude:

1. Determine which chart is to be utilized
2. Convert the pressure altitude and OAT to density altitude utilizing the Density Altitude chart (Figure 4-13)
3. Enter the appropriate climb chart at the desired density altitude and proceed horizontally to the planned gross weight.
4. At the planned gross weight proceed vertically down to the lower axis and read the predicted rate of climb.

## 4.7 Landing Distance

The Landing Distance charts (Figure 4-9, Sheets 1-6) provide the landing distances required to clear a 50 foot obstacle for all outside air temperatures, pressure altitudes and gross weights.

## 4.8 Height Velocity

The HV Chart (Figure 4-14) represents the factors of airspeed and height above ground, which represent a critical area of helicopter operation during takeoff and landing. The HV Chart was developed using a smooth, level, firm surface. The HV Chart is only valid when the WAT limitations (Figure 1-4) are not exceeded.

Prior to takeoffs made in accordance with the HV Chart proceed as follows:

Refer to Weight-Altitude-Temperature (WAT) Chart, Figure 1-4, for gross weight limit.

Determine the wind direction and speed. Downwind takeoffs are not recommended because published takeoff distances will not be achieved.

Determine torque required for hover at skid height of 4 feet. Refer to Figure 1.8: Power Limits for Takeoff.

• COPYRIGHT © 2007 BY EAGLE COPTERS MAINTENANCE LTD •

This document is private and confidential and is supplied on the express condition that it is not to be used for any purpose or copied or communicated to any other person without written permission from Eagle Copters Maintenance Ltd.

## 4.9 Operation vs Allowable Wind

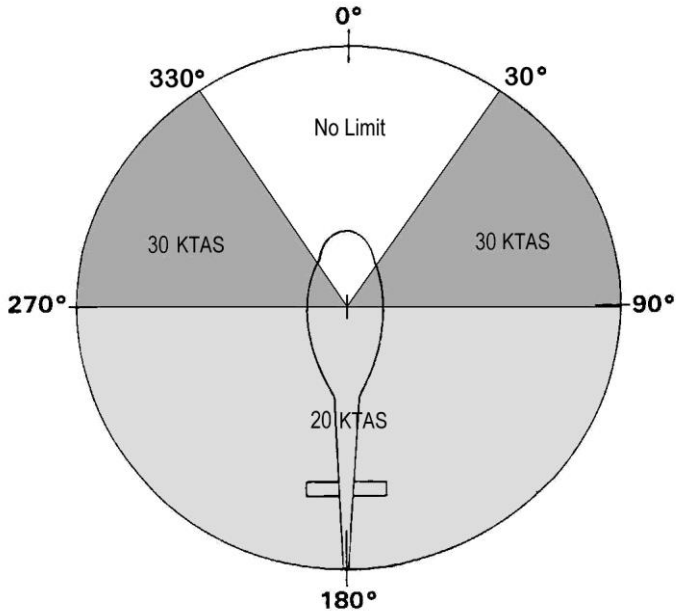

Figure 4-4 – Operation vs Allowable Wind Above 10,500 Lbs

• COPYRIGHT © 2007 BY EAGLE COPTERS MAINTENANCE LTD •

This document is private and confidential and is supplied on the express condition that it is not to be used for any purpose or copied or communicated to any other person without written permission from Eagle Copters Maintenance Ltd.

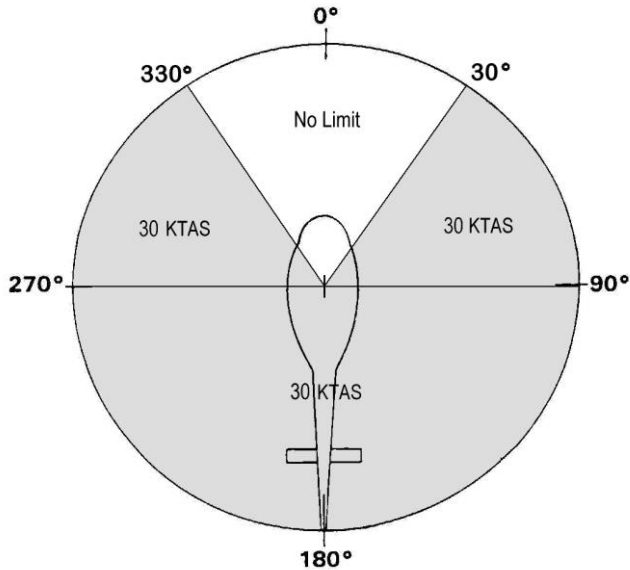

Figure 4-5 – Operation vs Allowable Wind 10,500 Lbs and Below

## 4.10 Airspeed System Calibration

Indicated airspeed (KIAS) correct for position and instrument error equals calibrated airspeed (KCAS). Determine corrected airspeed from Figure 4-8 and 4-9.

• COPYRIGHT © 2007 BY EAGLE COPTERS MAINTENANCE LTD •

This document is private and confidential and is supplied on the express condition that it is not to be used for any purpose or copied or communicated to any other person without written permission from Eagle Copters Maintenance Ltd.

## Hover Ceiling

In Ground Effect  
4 Foot Skid Height

Takeoff Power  
De-icing Off

Engine RPM 100%

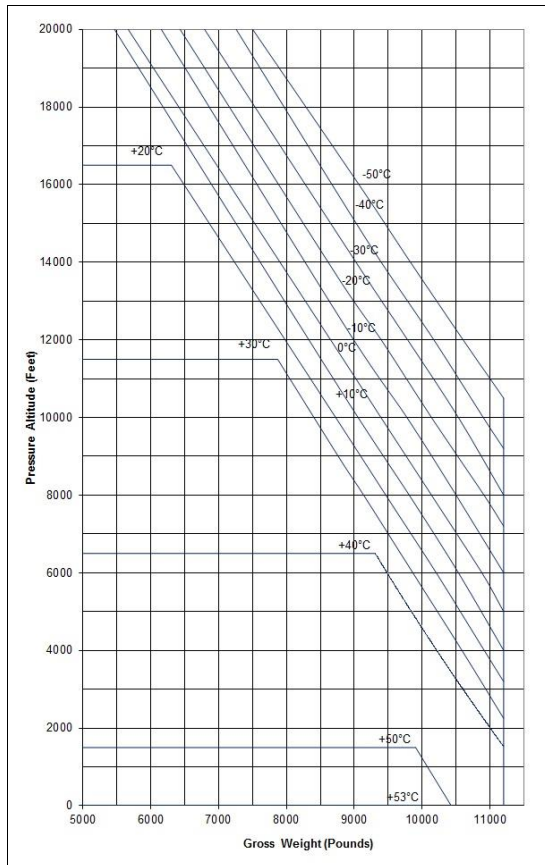

Figure 4-6 – Hover Ceiling (without Particle Separator) (Sheet 1 of 8)

• COPYRIGHT © 2007 BY EAGLE COPTERS MAINTENANCE LTD •

This document is private and confidential and is supplied on the express condition that it is not to be used for any purpose or copied or communicated to any other person without written permission from Eagle Copters Maintenance Ltd.

## Hover Ceiling

In Ground Effect  
4 Foot Skid Height

Takeoff Power  
De-icing On

Engine RPM 100%

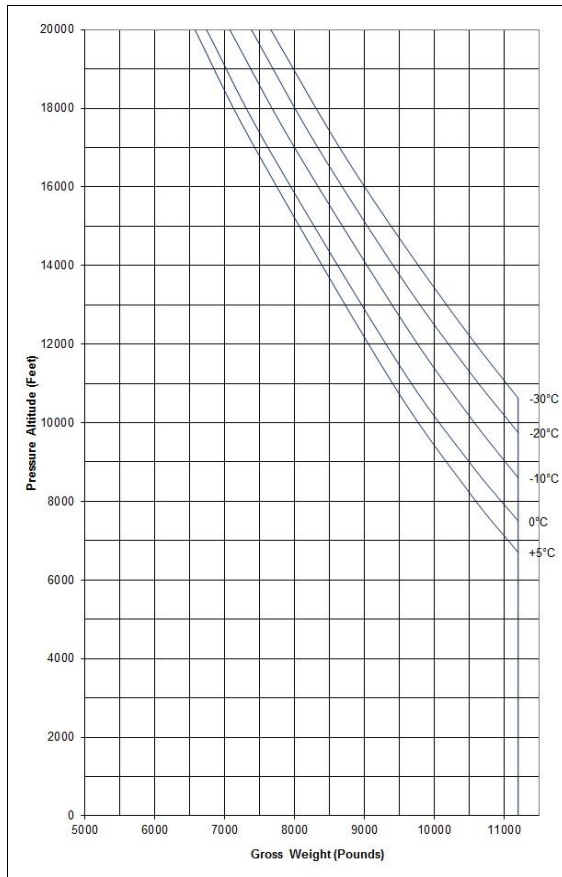

Figure 4-6 – Hover Ceiling (without Particle Separator) (Sheet 2 of 8)

• COPYRIGHT © 2007 BY EAGLE COPTERS MAINTENANCE LTD •

This document is private and confidential and is supplied on the express condition that it is not to be used for any purpose or copied or communicated to any other person without written permission from Eagle Copters Maintenance Ltd.

## Hover Ceiling

In Ground Effect  
4 Foot Skid Height

Max. Cont. Power  
De-icing Off

Engine RPM 100%

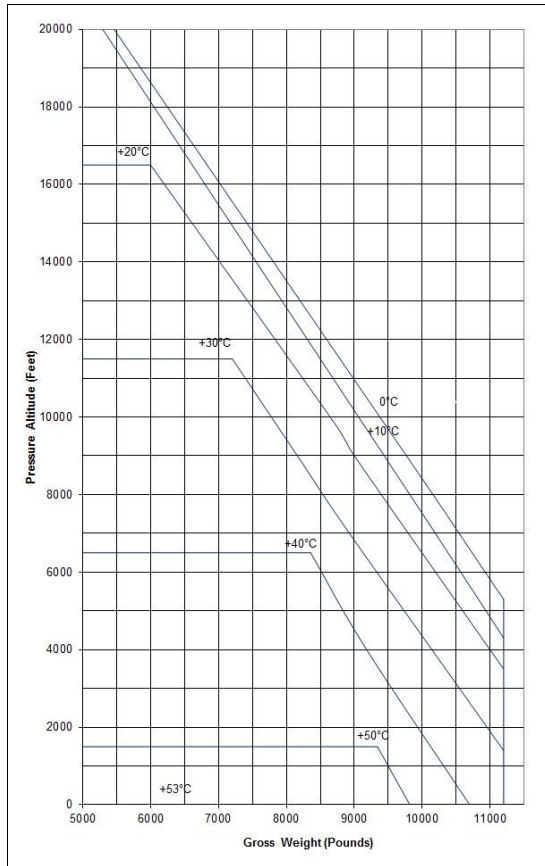

Figure 4-6 – Hover Ceiling (without Particle Separator) (Sheet 3 of 8)

• COPYRIGHT © 2007 BY EAGLE COPTERS MAINTENANCE LTD •

This document is private and confidential and is supplied on the express condition that it is not to be used for any purpose or copied or communicated to any other person without written permission from Eagle Copters Maintenance Ltd.

## Hover Ceiling

In Ground Effect  
4 Foot Skid Height

Max. Cont. Power  
De-icing On

Engine RPM 100%

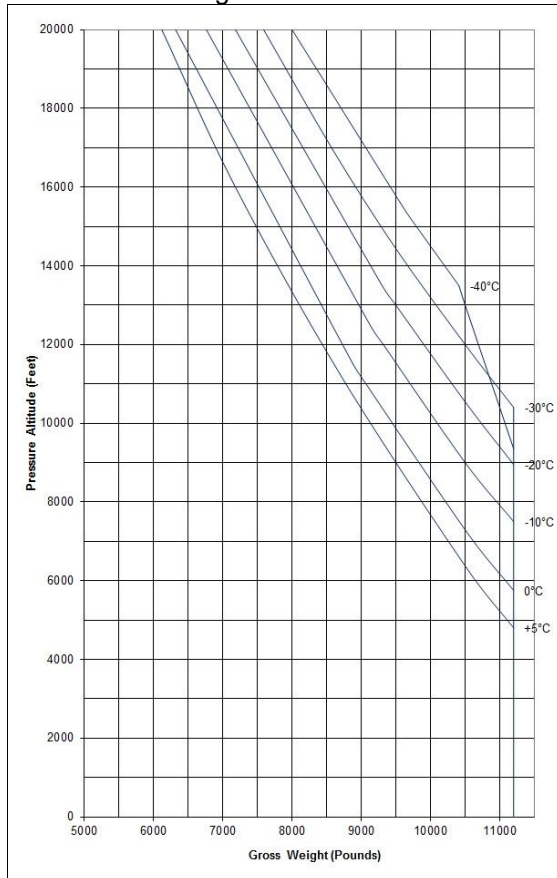

Figure 4-6 – Hover Ceiling (without Particle Separator) (Sheet 4 of 8)

• COPYRIGHT © 2007 BY EAGLE COPTERS MAINTENANCE LTD •

This document is private and confidential and is supplied on the express condition that it is not to be used for any purpose or copied or communicated to any other person without written permission from Eagle Copters Maintenance Ltd.

## Hover Ceiling

Out of Ground Effect  
60 Foot Skid Height

Takeoff Power  
De-icing Off

Engine RPM 100%

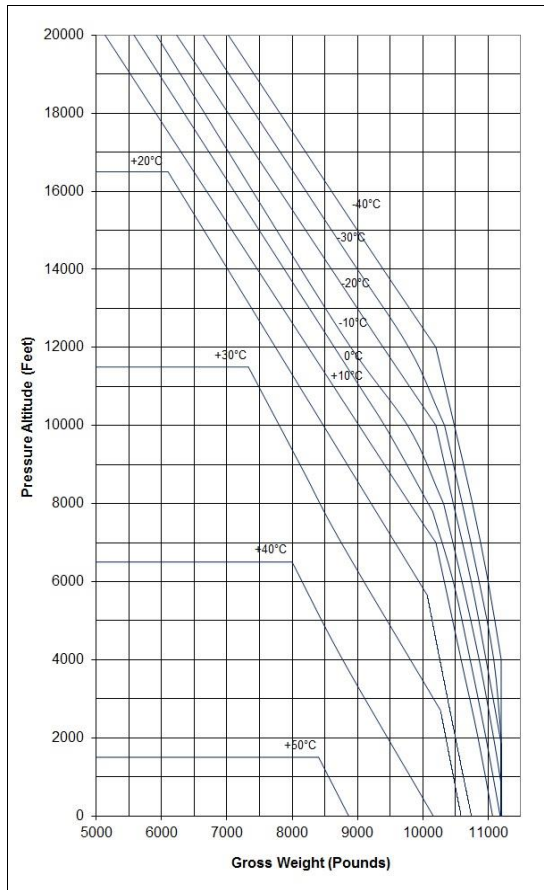

Figure 4-6 – Hover Ceiling (without Particle Separator) (Sheet 5 of 8)

• COPYRIGHT © 2007 BY EAGLE COPTERS MAINTENANCE LTD •

This document is private and confidential and is supplied on the express condition that it is not to be used for any purpose or copied or communicated to any other person without written permission from Eagle Copters Maintenance Ltd.

## Hover Ceiling

Out of Ground Effect  
60 Foot Skid Height

Takeoff Power  
De-icing On

Engine RPM 100%

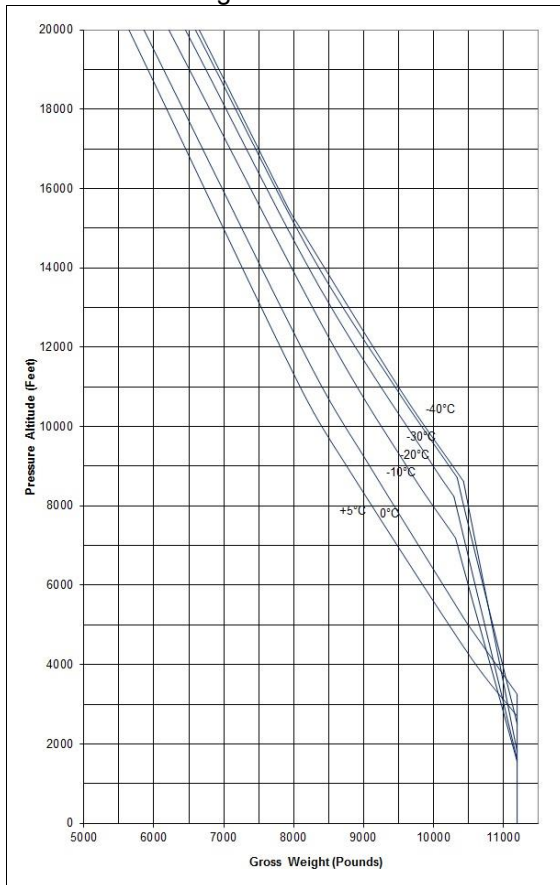

Figure 4-6 – Hover Ceiling (without Particle Separator) (Sheet 6 of 8)

• COPYRIGHT © 2007 BY EAGLE COPTERS MAINTENANCE LTD •

This document is private and confidential and is supplied on the express condition that it is not to be used for any purpose or copied or communicated to any other person without written permission from Eagle Copters Maintenance Ltd.

## Hover Ceiling

Out of Ground Effect  
60 Foot Skid Height

Max. Cont. Power  
De-icing Off

Engine RPM 100%

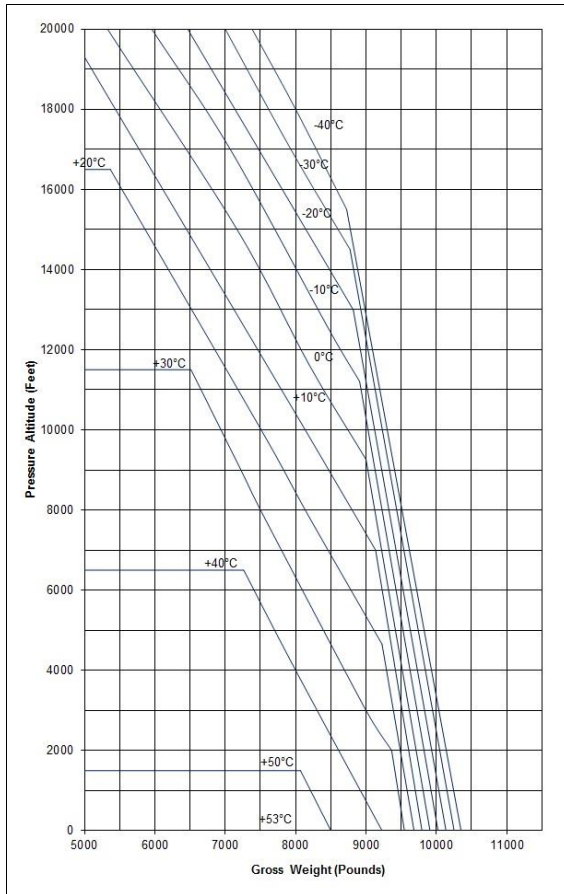

Figure 4-6 – Hover Ceiling (without Particle Separator) (Sheet 7 of 8)

• COPYRIGHT © 2007 BY EAGLE COPTERS MAINTENANCE LTD •

This document is private and confidential and is supplied on the express condition that it is not to be used for any purpose or copied or communicated to any other person without written permission from Eagle Copters Maintenance Ltd.

## Hover Ceiling

Out of Ground Effect  
60 Foot Skid Height

Max. Cont. Power  
De-icing On

Engine RPM 100%

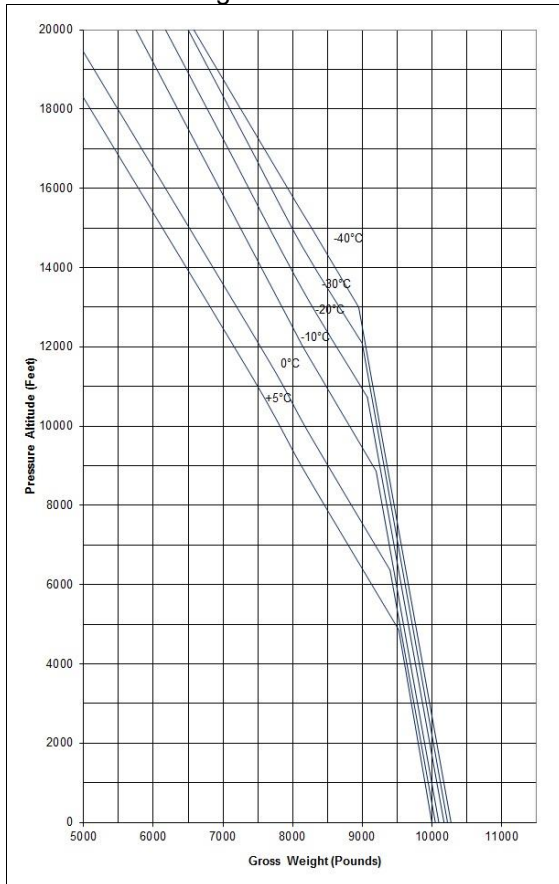

Figure 4-6 – Hover Ceiling (without Particle Separator) (Sheet 8 of 8)

• COPYRIGHT © 2007 BY EAGLE COPTERS MAINTENANCE LTD •

This document is private and confidential and is supplied on the express condition that it is not to be used for any purpose or copied or communicated to any other person without written permission from Eagle Copters Maintenance Ltd.

# Takeoff Distance Over 50 Foot Obstacle Takeoff Power

Gross Weight 6500 Lbs

65 KIAS  
Engine RPM 100%

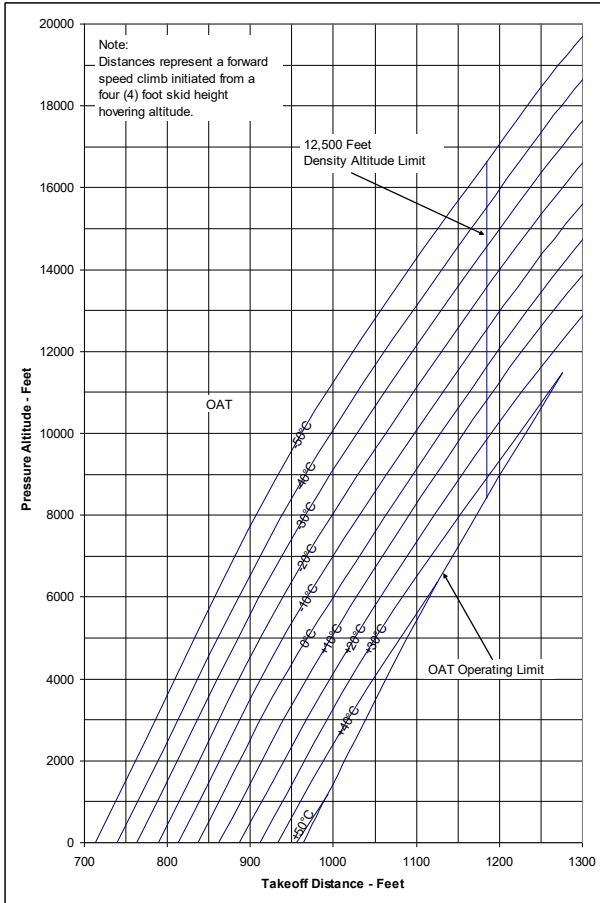

Figure 4-7 – Takeoff Distance (Sheet 1 of 12)

• COPYRIGHT © 2007 BY EAGLE COPTERS MAINTENANCE LTD •

This document is private and confidential and is supplied on the express condition that it is not to be used for any purpose or copied or communicated to any other person without written permission from Eagle Copters Maintenance Ltd.

# Takeoff Distance

Over 50 Foot Obstacle

Takeoff Power

De-icing On  
Gross Weight 6500 Lbs

65 KIAS  
Engine RPM 100%

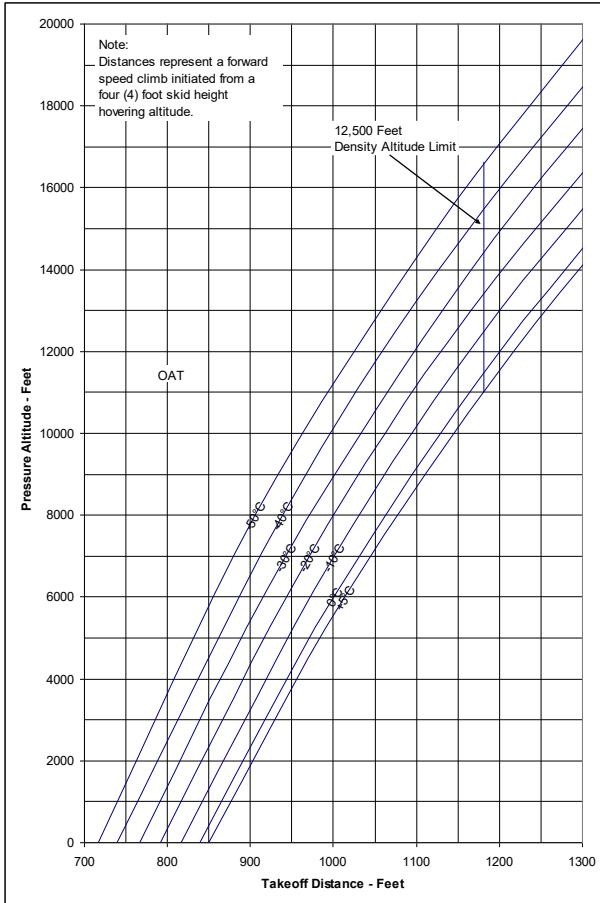

Figure 4-7 – Takeoff Distance (Sheet 2 of 12)

• COPYRIGHT © 2007 BY EAGLE COPTERS MAINTENANCE LTD •

This document is private and confidential and is supplied on the express condition that it is not to be used for any purpose or copied or communicated to any other person without written permission from Eagle Copters Maintenance Ltd.

## Takeoff Distance Over 50 Foot Obstacle Takeoff Power

Gross Weight 7500 Lbs

65 KIAS  
Engine RPM 100%

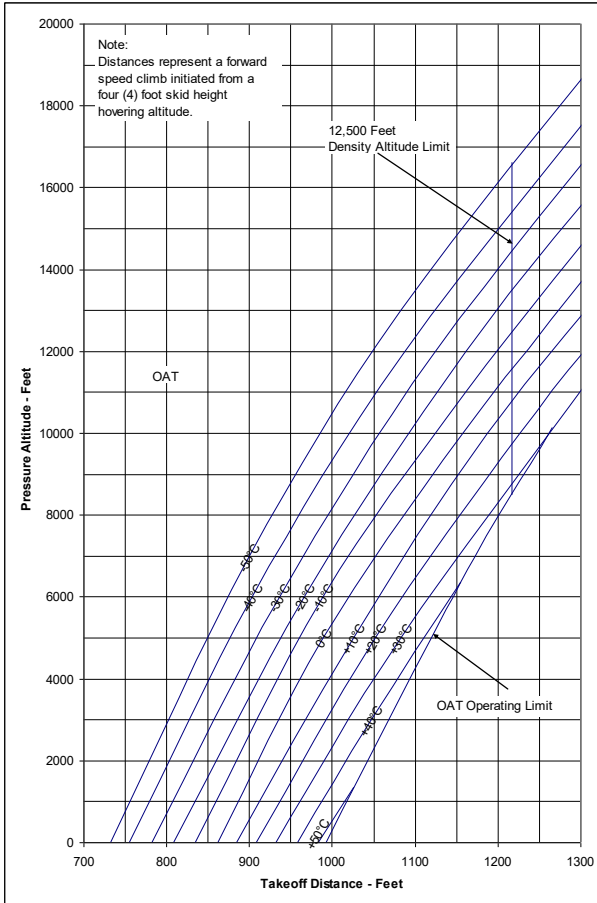

Figure 4-7 – Takeoff Distance (Sheet 3 of 12)

**• COPYRIGHT © 2007 BY EAGLE COPTERS MAINTENANCE LTD •**

This document is private and confidential and is supplied on the express condition that it is not to be used for any purpose or copied or communicated to any other person without written permission from Eagle Copters Maintenance Ltd.

## Takeoff Distance Over 50 Foot Obstacle Takeoff Power

De-icing On  
Gross Weight 7500 Lbs

65 KIAS  
Engine RPM 100%

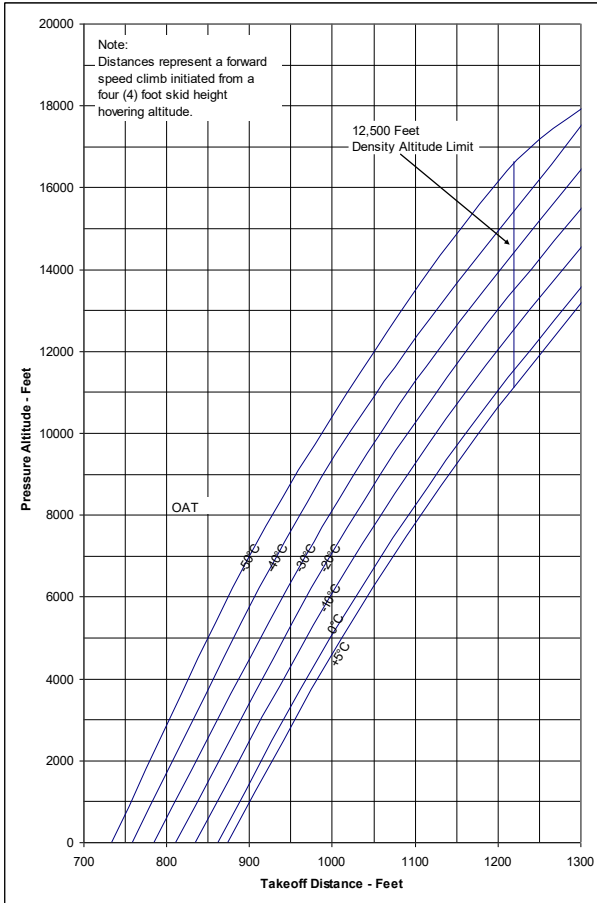

Figure 4-7 – Takeoff Distance (Sheet 4 of 12)

• COPYRIGHT © 2007 BY EAGLE COPTERS MAINTENANCE LTD •

This document is private and confidential and is supplied on the express condition that it is not to be used for any purpose or copied or communicated to any other person without written permission from Eagle Copters Maintenance Ltd.

## Takeoff Distance Over 50 Foot Obstacle Takeoff Power

Gross Weight 8500 Lbs

65 KIAS  
Engine RPM 100%

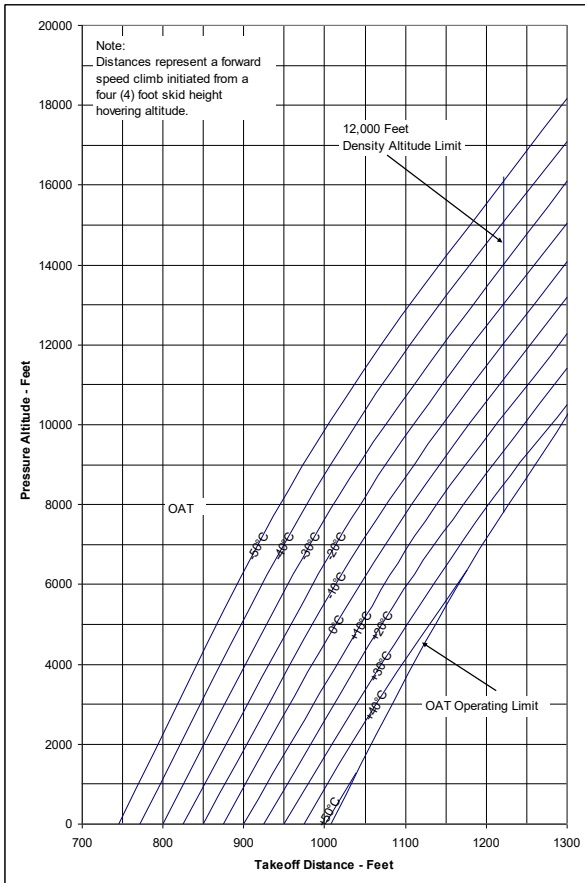

Figure 4-7 – Takeoff Distance (Sheet 5 of 12)

**• COPYRIGHT © 2007 BY EAGLE COPTERS MAINTENANCE LTD •**

This document is private and confidential and is supplied on the express condition that it is not to be used for any purpose or copied or communicated to any other person without written permission from Eagle Copters Maintenance Ltd.

## Takeoff Distance Over 50 Foot Obstacle Takeoff Power

De-icing On  
Gross Weight 8500 Lbs

65 KIAS  
Engine RPM 100%

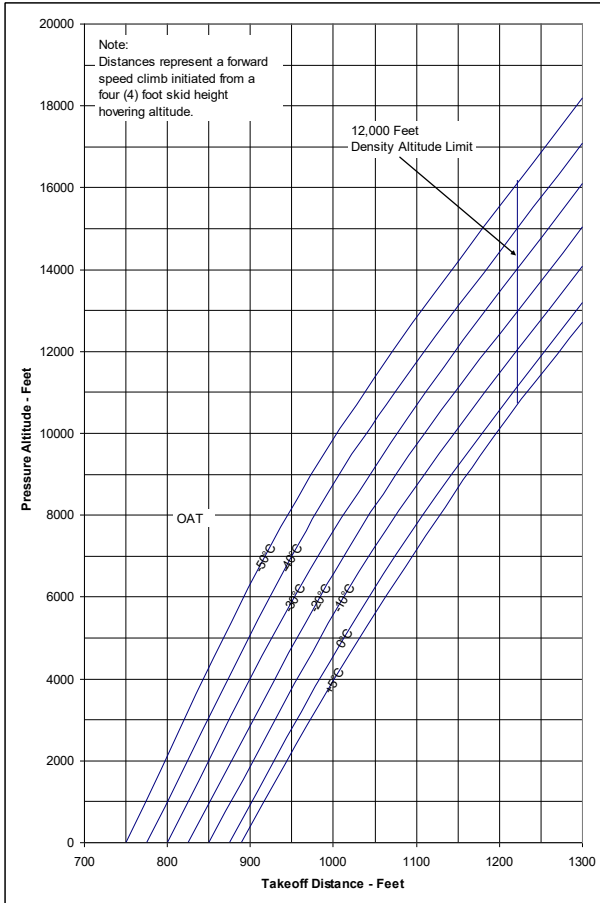

Figure 4-7 – Takeoff Distance (Sheet 6 of 12)

• COPYRIGHT © 2007 BY EAGLE COPTERS MAINTENANCE LTD •

This document is private and confidential and is supplied on the express condition that it is not to be used for any purpose or copied or communicated to any other person without written permission from Eagle Copters Maintenance Ltd.



# Takeoff Distance Over 50 Foot Obstacle Takeoff Power

Gross Weight 9500 Lbs

65 KIAS  
Engine RPM 100%

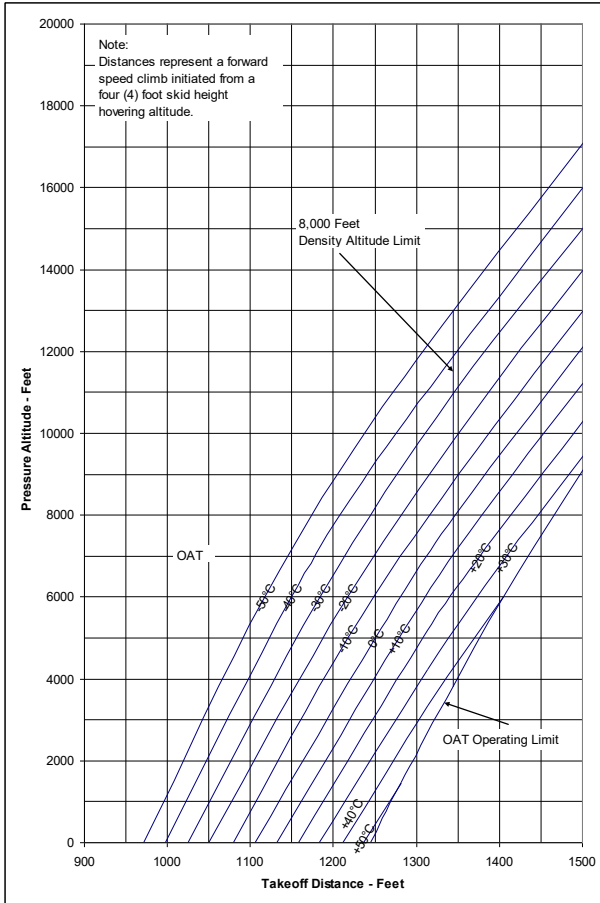

Figure 4-7 – Takeoff Distance (Sheet 7 of 12)

• COPYRIGHT © 2007 BY EAGLE COPTERS MAINTENANCE LTD •

This document is private and confidential and is supplied on the express condition that it is not to be used for any purpose or copied or communicated to any other person without written permission from Eagle Copters Maintenance Ltd.

# Takeoff Distance Over 50 Foot Obstacle Takeoff Power

De-icing On  
Gross Weight 9500 Lbs

65 KIAS  
Engine RPM 100%

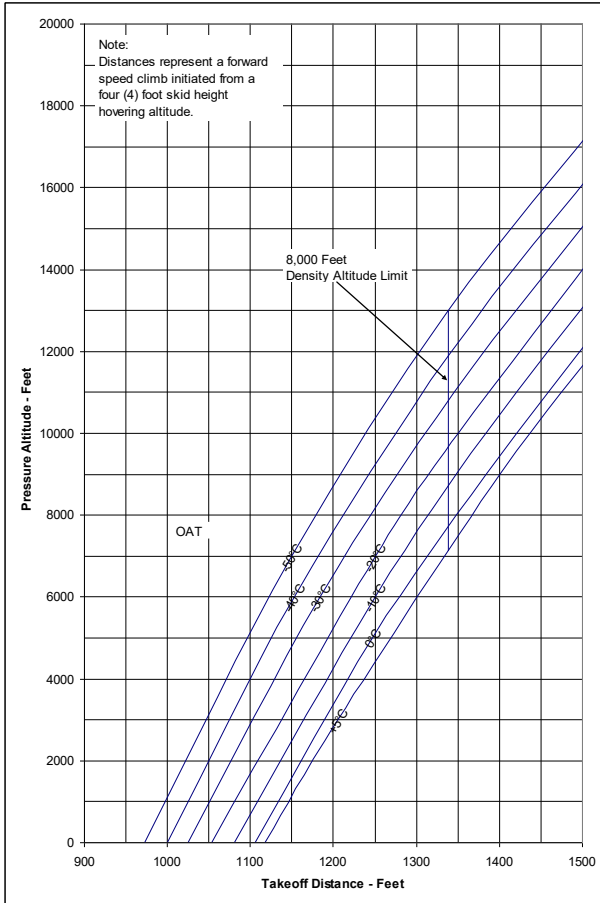

Figure 4-7 – Takeoff Distance (Sheet 8 of 12)

• COPYRIGHT © 2007 BY EAGLE COPTERS MAINTENANCE LTD •

This document is private and confidential and is supplied on the express condition that it is not to be used for any purpose or copied or communicated to any other person without written permission from Eagle Copters Maintenance Ltd.

# Takeoff Distance Over 50 Foot Obstacle Takeoff Power

Gross Weight 10,500 Lbs

65 KIAS  
Engine RPM 100%

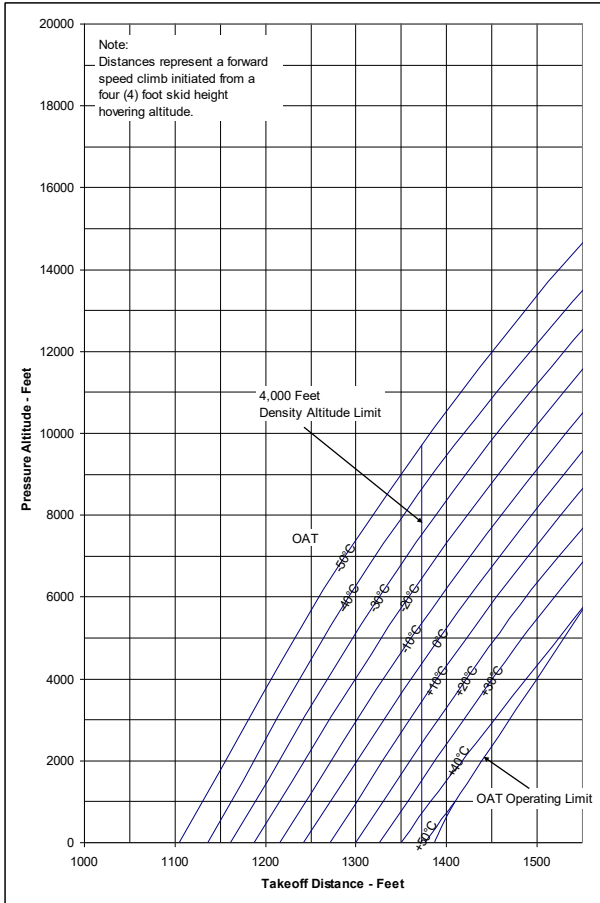

Figure 4-7 – Takeoff Distance (Sheet 9 of 12)

• COPYRIGHT © 2007 BY EAGLE COPTERS MAINTENANCE LTD •

This document is private and confidential and is supplied on the express condition that it is not to be used for any purpose or copied or communicated to any other person without written permission from Eagle Copters Maintenance Ltd.

## Takeoff Distance Over 50 Foot Obstacle Takeoff Power

De-icing On  
Gross Weight 10,500 Lbs

65 KIAS  
Engine RPM 100%

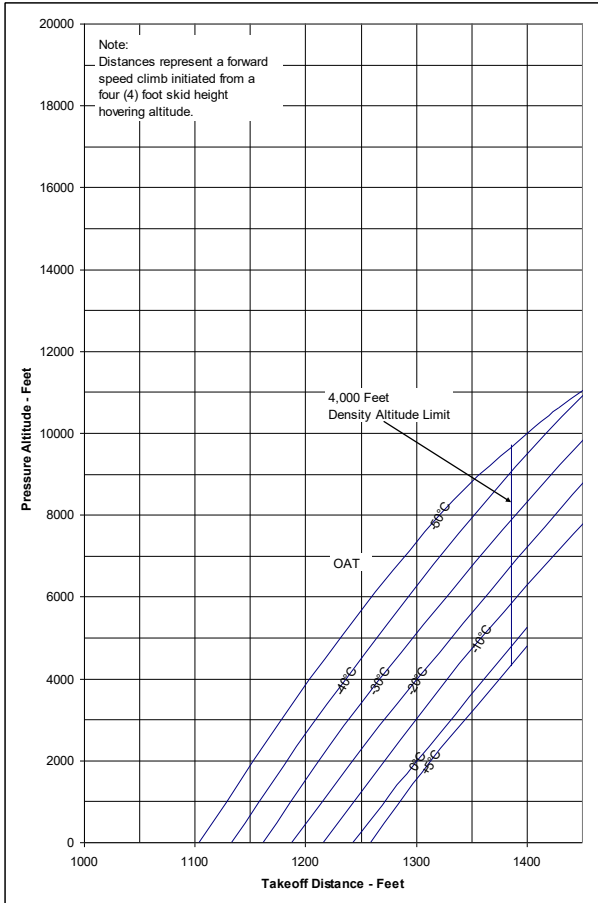

Figure 4-7 – Takeoff Distance (Sheet 10 of 12)

• COPYRIGHT © 2007 BY EAGLE COPTERS MAINTENANCE LTD •

This document is private and confidential and is supplied on the express condition that it is not to be used for any purpose or copied or communicated to any other person without written permission from Eagle Copters Maintenance Ltd.

## Takeoff Distance Over 50 Foot Obstacle Takeoff Power

Gross Weight 11,200 Lbs

65 KIAS  
Engine RPM 100%

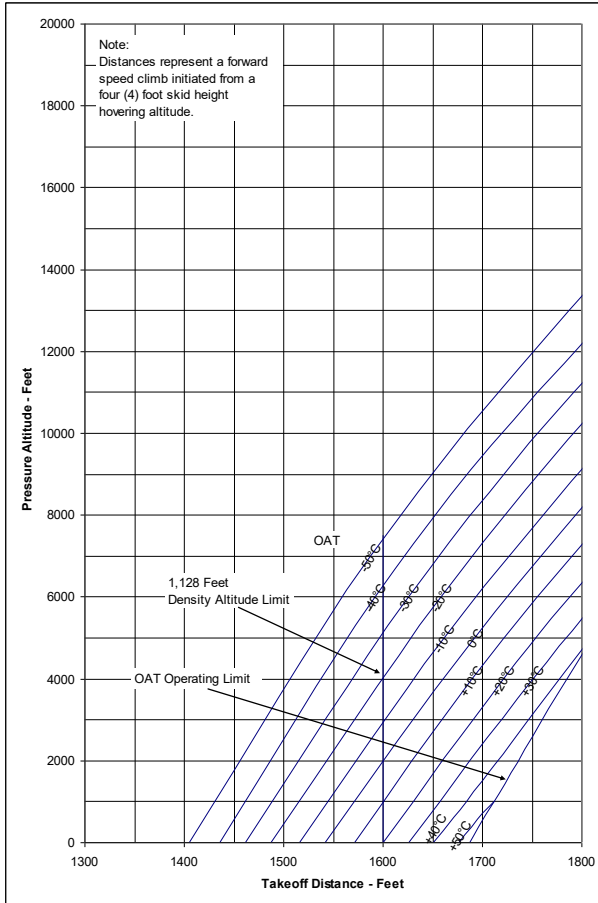

Figure 4-7 – Takeoff Distance (Sheet 11 of 12)

**• COPYRIGHT © 2007 BY EAGLE COPTERS MAINTENANCE LTD •**

This document is private and confidential and is supplied on the express condition that it is not to be used for any purpose or copied or communicated to any other person without written permission from Eagle Copters Maintenance Ltd.

## Takeoff Distance Over 50 Foot Obstacle Takeoff Power

De-icing On  
Gross Weight 11,200 Lbs

65 KIAS  
Engine RPM 100%

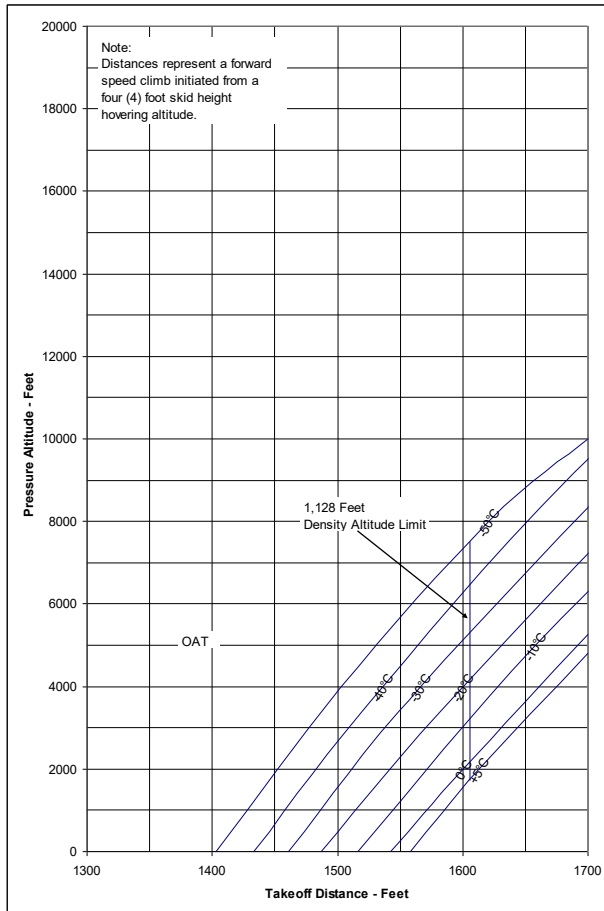

Figure 4-7 – Takeoff Distance (Sheet 12 of 12)

• COPYRIGHT © 2007 BY EAGLE COPTERS MAINTENANCE LTD •

This document is private and confidential and is supplied on the express condition that it is not to be used for any purpose or copied or communicated to any other person without written permission from Eagle Copters Maintenance Ltd.

## Rate of Climb – Maximum Takeoff Power

De-ice Off

65 KIAS

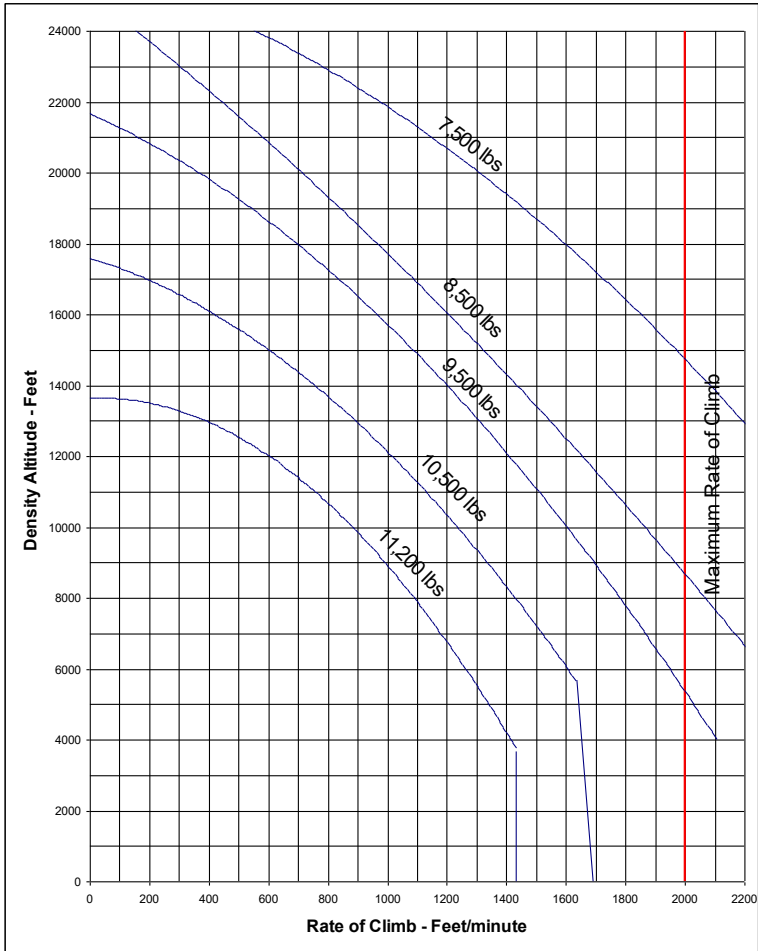

Figure 4-8 – Rate of Climb – Maximum (Sheet 1 of 2)

• COPYRIGHT © 2007 BY EAGLE COPTERS MAINTENANCE LTD •

This document is private and confidential and is supplied on the express condition that it is not to be used for any purpose or copied or communicated to any other person without written permission from Eagle Copters Maintenance Ltd.

## Rate of Climb – Maximum

Max Continuous Power

65 KIAS

De-ice On

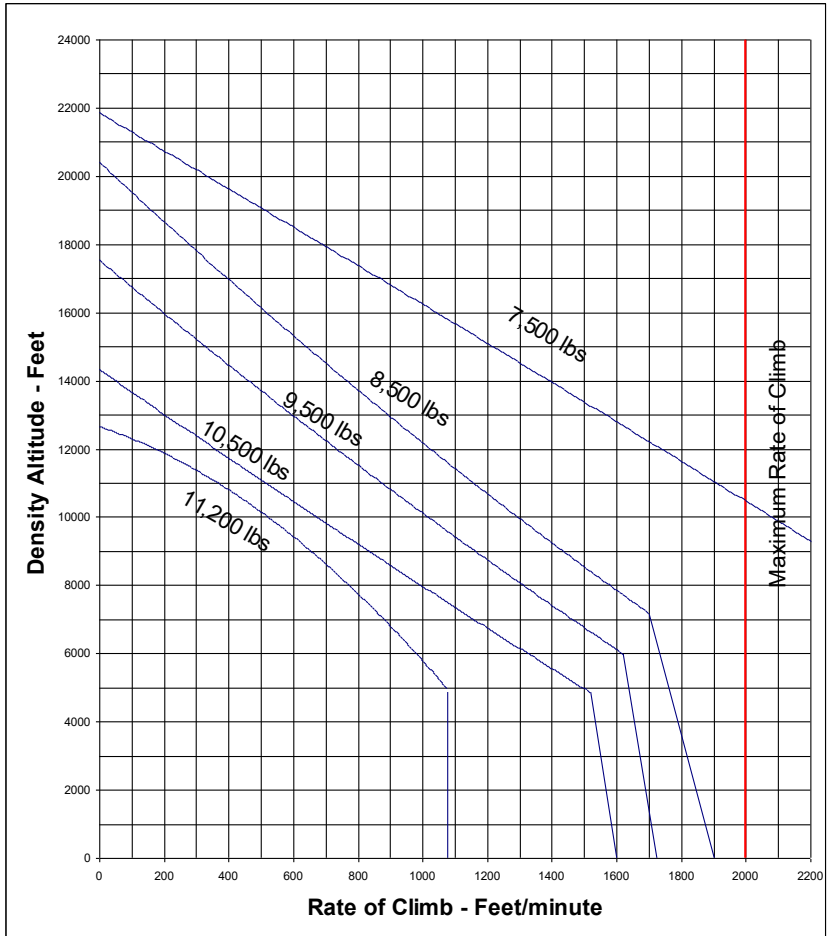

Figure 4-8 – Rate of Climb – Maximum (Sheet 2 of 2)

• COPYRIGHT © 2007 BY EAGLE COPTERS MAINTENANCE LTD •

This document is private and confidential and is supplied on the express condition that it is not to be used for any purpose or copied or communicated to any other person without written permission from Eagle Copters Maintenance Ltd.

## Landing Distance Over 50 Foot Obstacle

Gross Weight  
6,500 Lbs

65 KIAS

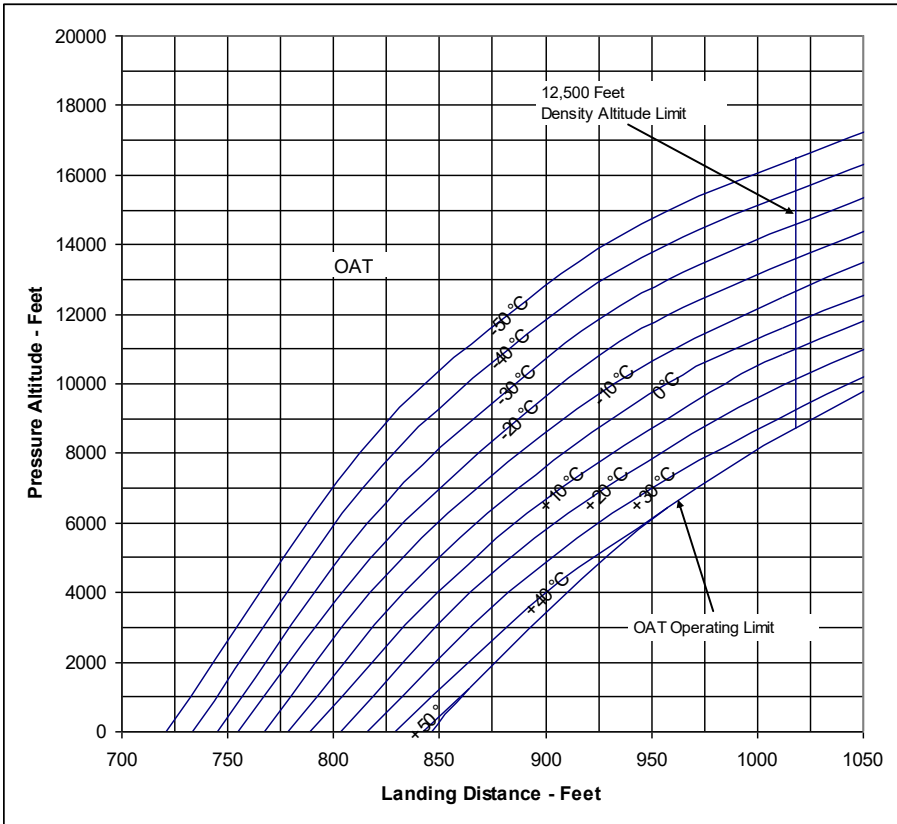

Figure 4-9 – Landing Distance (Sheet 1 of 6)

• COPYRIGHT © 2007 BY EAGLE COPTERS MAINTENANCE LTD •

This document is private and confidential and is supplied on the express condition that it is not to be used for any purpose or copied or communicated to any other person without written permission from Eagle Copters Maintenance Ltd.

## Landing Distance Over 50 Foot Obstacle

Gross Weight  
7,500 Lbs

65 KIAS

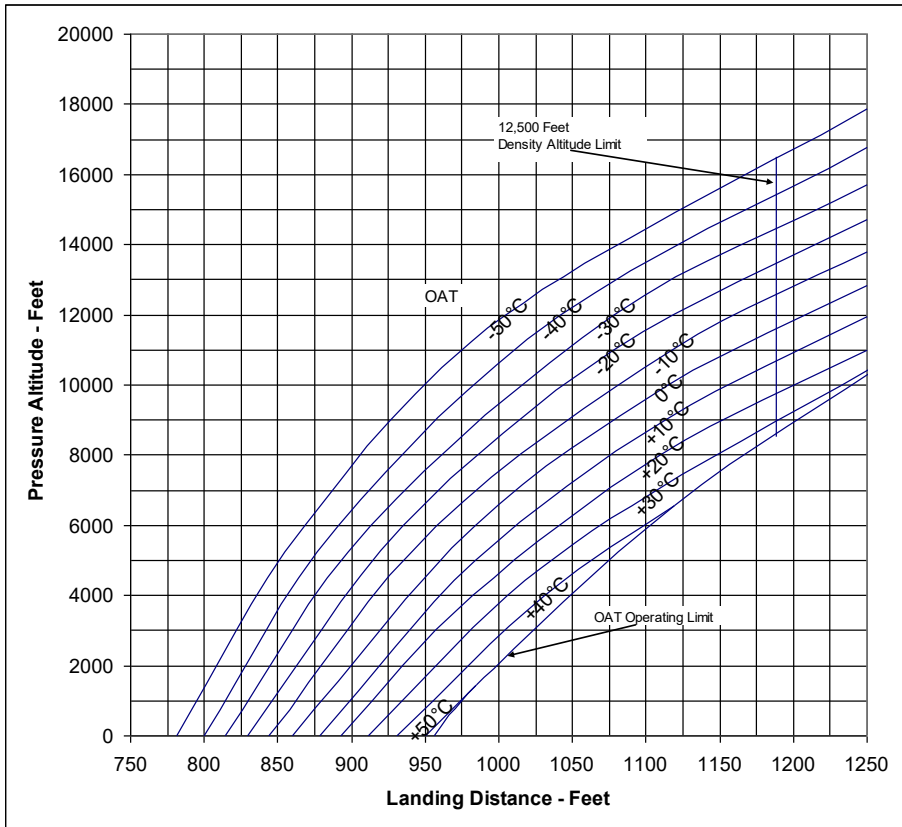

Figure 4-9 – Landing Distance (Sheet 2 of 6)

**• COPYRIGHT © 2007 BY EAGLE COPTERS MAINTENANCE LTD •**

This document is private and confidential and is supplied on the express condition that it is not to be used for any purpose or copied or communicated to any other person without written permission from Eagle Copters Maintenance Ltd.

## Landing Distance Over 50 Foot Obstacle

Gross Weight  
8,500 Lbs

65 KIAS

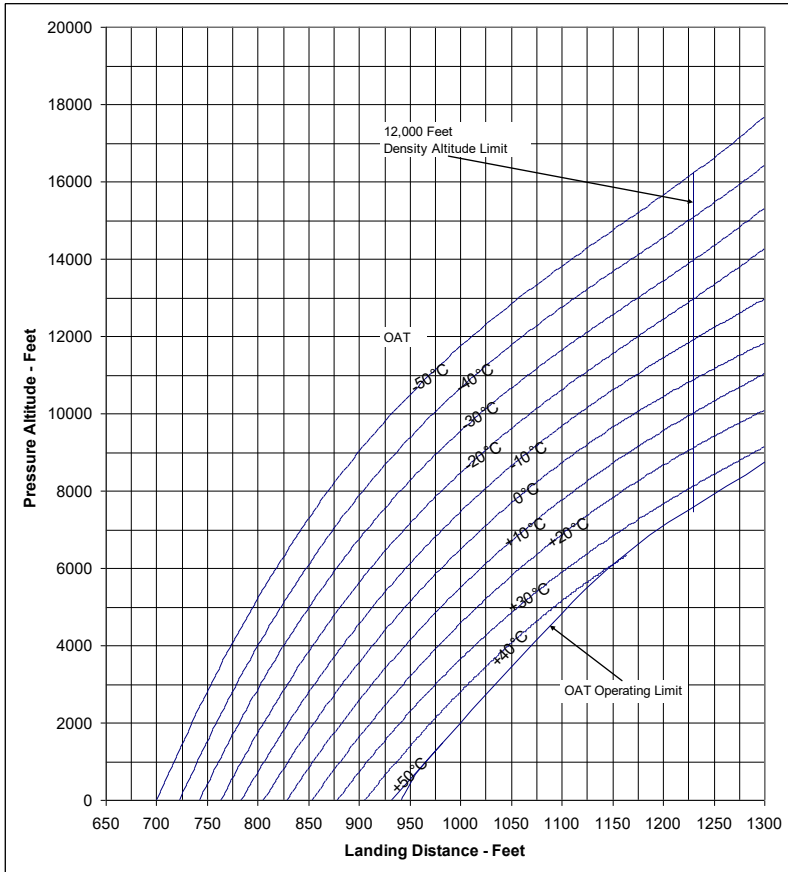

Figure 4-9 – Landing Distance (Sheet 3 of 6)

**• COPYRIGHT © 2007 BY EAGLE COPTERS MAINTENANCE LTD •**

This document is private and confidential and is supplied on the express condition that it is not to be used for any purpose or copied or communicated to any other person without written permission from Eagle Copters Maintenance Ltd.

## Landing Distance Over 50 Foot Obstacle

Gross Weight  
9,500 Lbs

65 KIAS

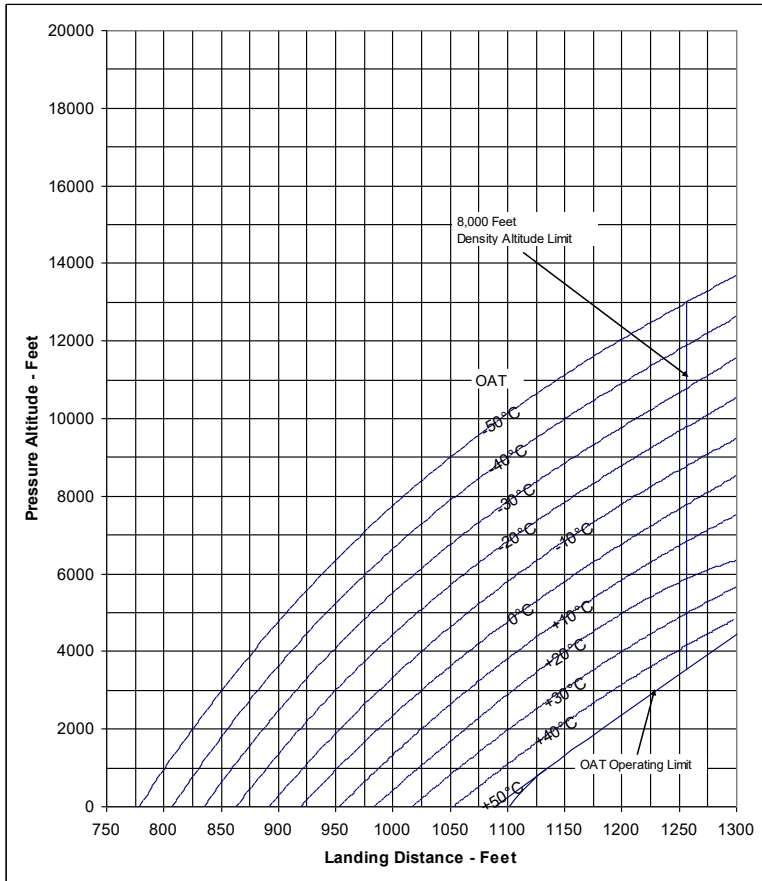

Figure 4-9 – Landing Distance (Sheet 4 of 6)

**• COPYRIGHT © 2007 BY EAGLE COPTERS MAINTENANCE LTD •**

This document is private and confidential and is supplied on the express condition that it is not to be used for any purpose or copied or communicated to any other person without written permission from Eagle Copters Maintenance Ltd.

## Landing Distance Over 50 Foot Obstacle

Gross Weight  
10,500 Lbs

65 KIAS

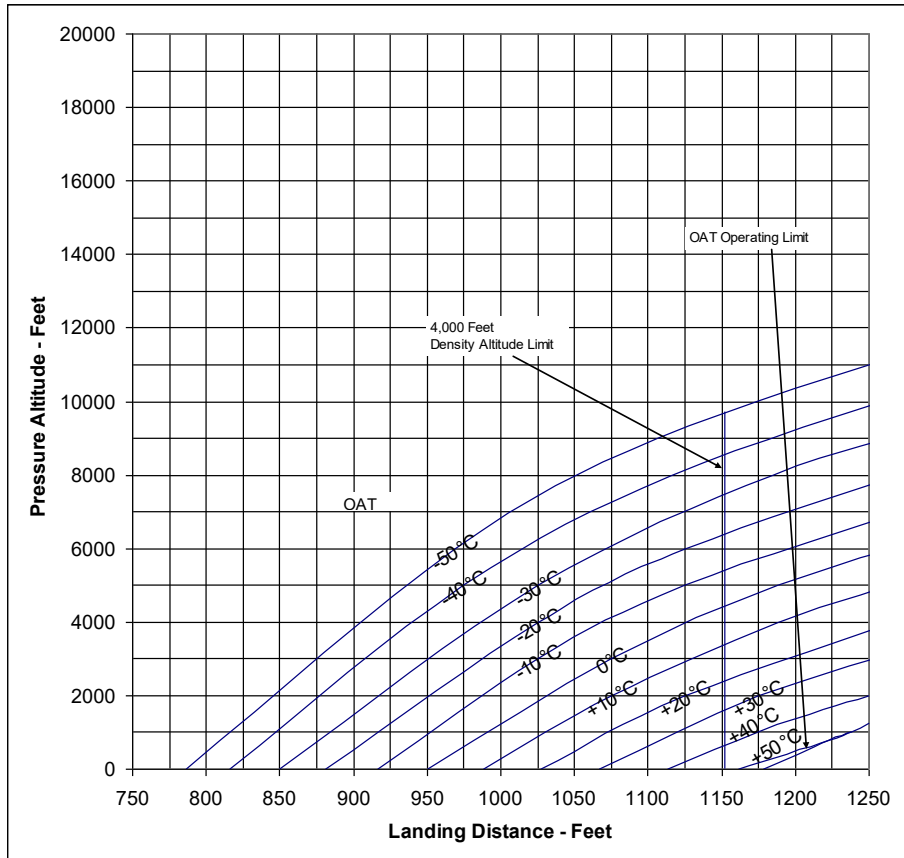

Figure 4-9 – Landing Distance (Sheet 5 of 6)

• COPYRIGHT © 2007 BY EAGLE COPTERS MAINTENANCE LTD •

This document is private and confidential and is supplied on the express condition that it is not to be used for any purpose or copied or communicated to any other person without written permission from Eagle Copters Maintenance Ltd.

## Landing Distance Over 50 Foot Obstacle

Gross Weight  
11,200 Lbs

65 KIAS

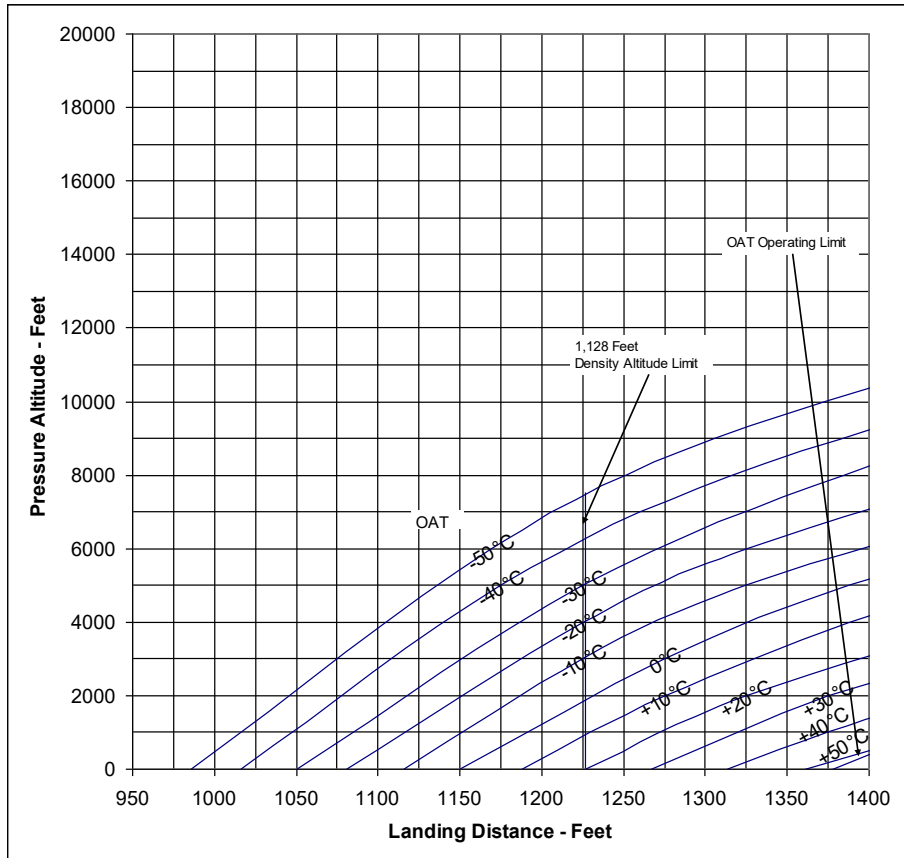

Figure 4-9 – Landing Distance (Sheet 6 of 6)

• COPYRIGHT © 2007 BY EAGLE COPTERS MAINTENANCE LTD •

This document is private and confidential and is supplied on the express condition that it is not to be used for any purpose or copied or communicated to any other person without written permission from Eagle Copters Maintenance Ltd.

## Pilot Airspeed System Calibration

Climb  
Level Flight  
Autorotation

Indicated Airspeed – Error = Calibrated Airspeed

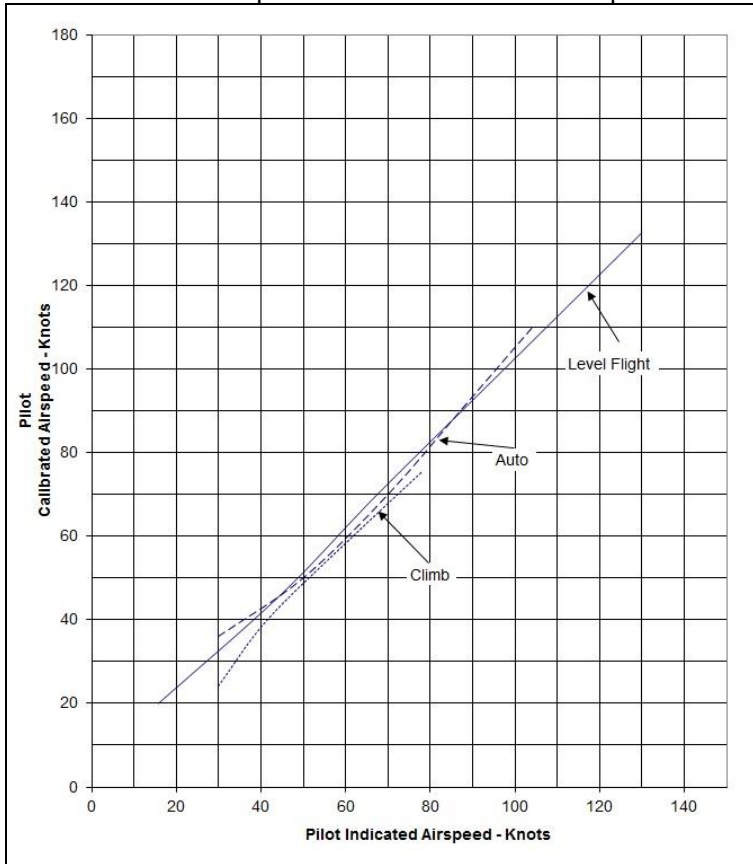

Figure 4-10 – Pilot Airspeed System Calibration

• COPYRIGHT © 2007 BY EAGLE COPTERS MAINTENANCE LTD •

This document is private and confidential and is supplied on the express condition that it is not to be used for any purpose or copied or communicated to any other person without written permission from Eagle Copters Maintenance Ltd.

## Copilot Airspeed System Calibration

Climb  
Level Flight  
Autorotation

Indicated Airspeed – Error = Calibrated Airspeed

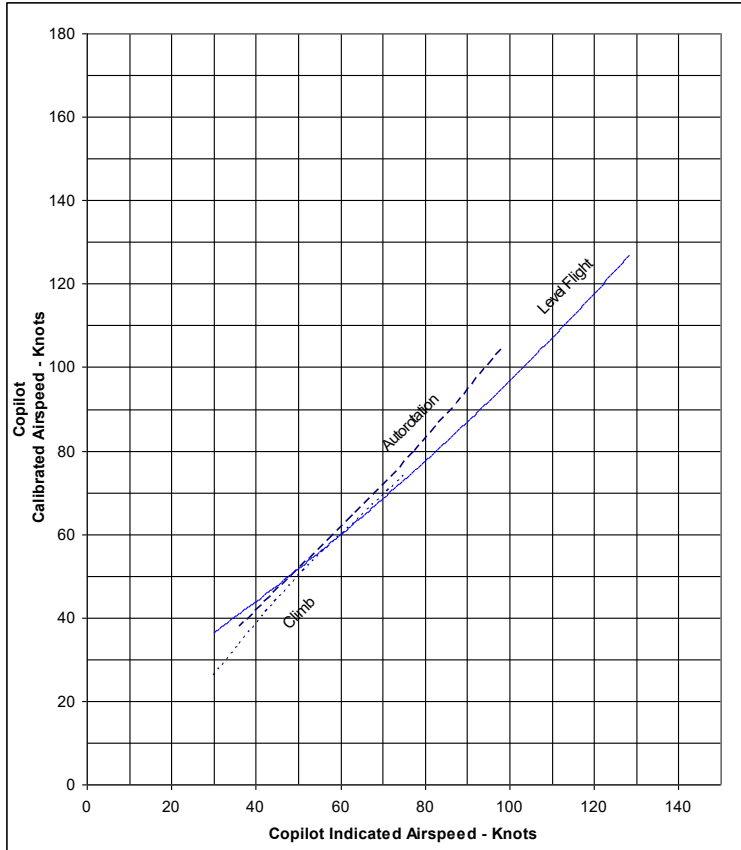

Figure 4-11 – Copilot Airspeed System Calibration

• COPYRIGHT © 2007 BY EAGLE COPTERS MAINTENANCE LTD •

This document is private and confidential and is supplied on the express condition that it is not to be used for any purpose or copied or communicated to any other person without written permission from Eagle Copters Maintenance Ltd.

## Autorotative Glide Distance

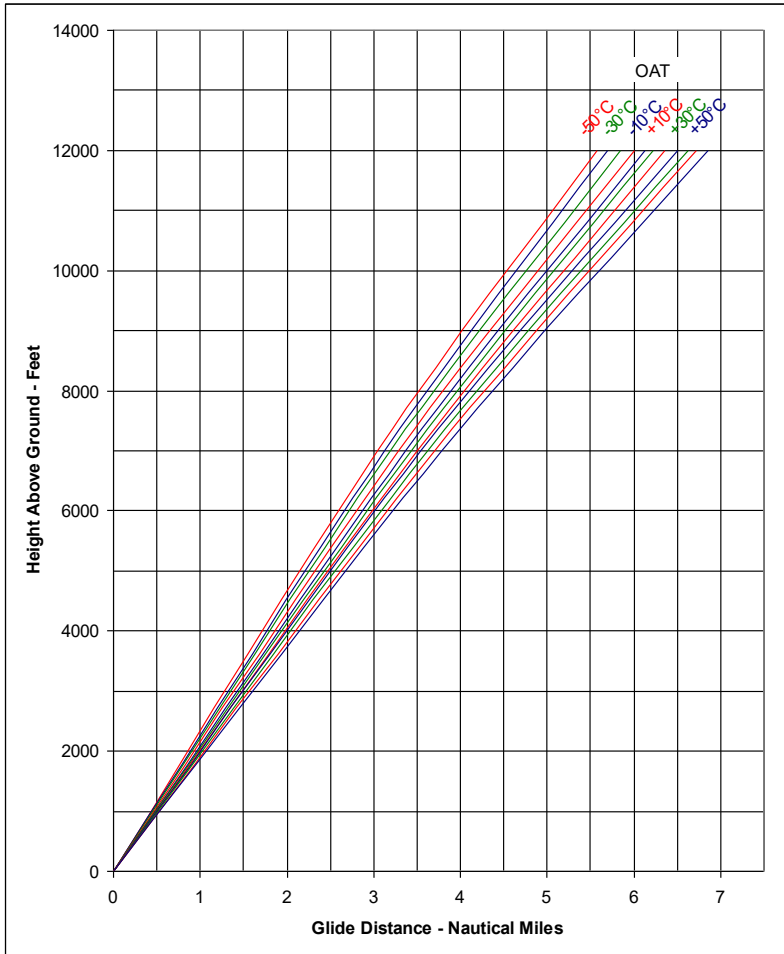

Figure 4-12 – Glide Distance

• COPYRIGHT © 2007 BY EAGLE COPTERS MAINTENANCE LTD •

This document is private and confidential and is supplied on the express condition that it is not to be used for any purpose or copied or communicated to any other person without written permission from Eagle Copters Maintenance Ltd.

## Density Altitude – Pressure Altitude

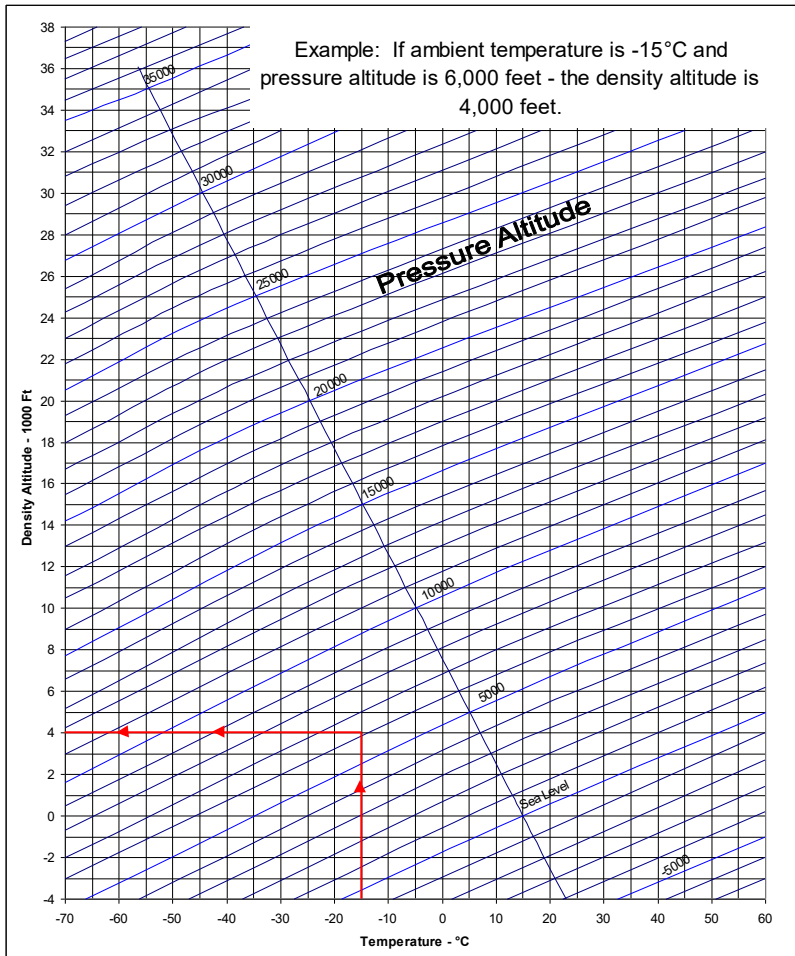

Figure 4-13 – Density Altitude – Pressure Altitude

• COPYRIGHT © 2007 BY EAGLE COPTERS MAINTENANCE LTD •

This document is private and confidential and is supplied on the express condition that it is not to be used for any purpose or copied or communicated to any other person without written permission from Eagle Copters Maintenance Ltd.

## Height Velocity Chart

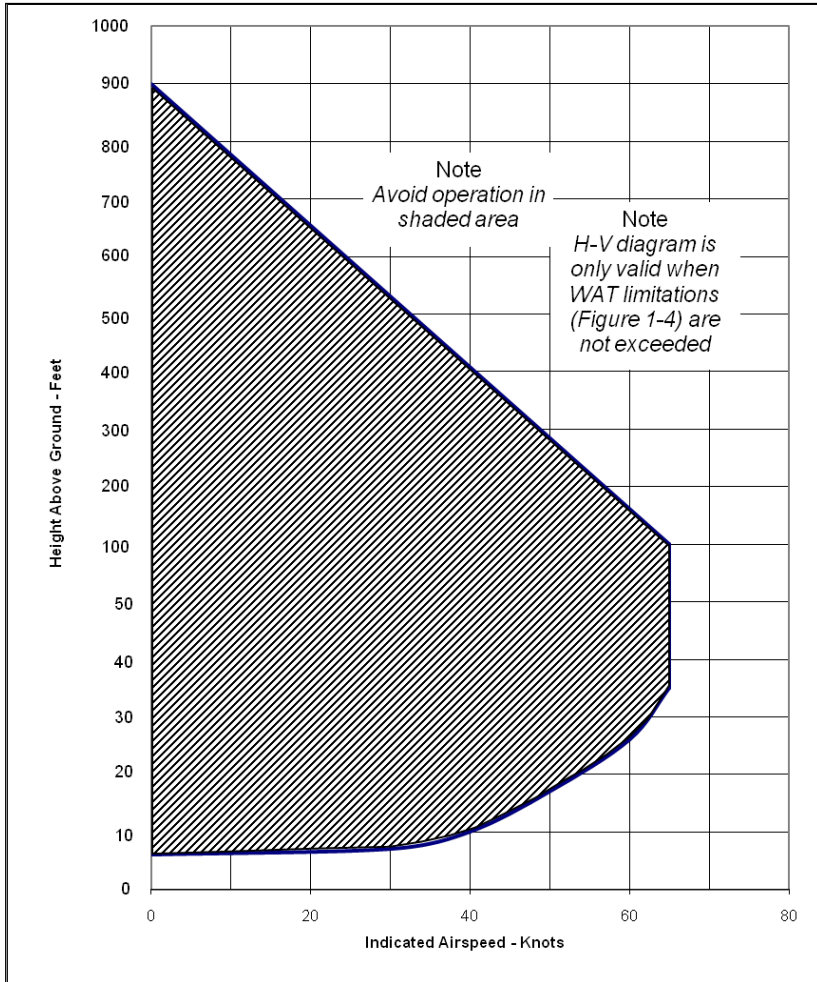

Figure 4-14 – Height Velocity Chart

• COPYRIGHT © 2007 BY EAGLE COPTERS MAINTENANCE LTD •

This document is private and confidential and is supplied on the express condition that it is not to be used for any purpose or copied or communicated to any other person without written permission from Eagle Copters Maintenance Ltd.

## Section 5

### *Weight and Balance Data and Optional System Descriptions*

#### Table of Contents

|       |   |    |
|-------|---|----|
| 5.1   | Introduction.....                                 | 3  |
| 5.2   | Empty Weight Center of Gravity.....               | 3  |
| 5.3   | Gross Weight Center of Gravity .....              | 3  |
| 5.4   | Doors Open or Removed .....                       | 4  |
| 5.5   | Cockpit and Cabin Loading .....                   | 4  |
| 5.5.1 | Cabin Deck Loading .....                          | 4  |
| 5.5.2 | Internal Cargo Loading Table.....                 | 5  |
| 5.6   | Cargo Compartment Loading.....                    | 5  |
| 5.6.1 | Cargo Loading.....                                | 5  |
| 5.6.2 | Cargo Loading Table.....                          | 5  |
| 5.7   | Fuel Loading.....                                 | 5  |
| 5.7.1 | Computation of CG.....                            | 6  |
| 5.7.2 | Sample Loading Problem .....                      | 6  |
| 5.8   | Optional System Descriptions .....                | 24 |
| 5.8.1 | USB Charging Ports .....                          | 24 |
| 5.8.2 | Dual Digital Clocks with USB Charging Ports ..... | 24 |

• COPYRIGHT © 2007 BY EAGLE COPTERS MAINTENANCE LTD •

This document is private and confidential and is supplied on the express condition that it is not to be used for any purpose or copied or communicated to any other person without written permission from Eagle Copters Maintenance Ltd.

Unapproved

Revision: **M**

Date: 2026-04-13



### List of Figures and Tables

|  |      |
|--|------|
| Table 5-1 – Sample Loading Problem (English Units).....        | 5-7  |
| Table 5-2 – Sample Loading Problem (Metric Units).....         | 5-8  |
| Figure 5-1 – Helicopter Station Diagram.....                   | 5-9  |
| Table 5-3 – Door Weights and Moments .....                     | 5-10 |
| Table 5-4 – Crew and passenger table of moments.....           | 5-11 |
| Table 5-5 – Crew and Passenger Table of Moments (Cont'd) ..... | 5-12 |
| Table 5-6 – Internal Cargo Loading .....                       | 5-13 |
| Table 5-7 – Internal Cargo Loading (Cont'd) .....              | 5-15 |
| Table 5-8 – Cargo Loading .....                                | 5-17 |
| Table 5-9 – Fuel Loading .....                                 | 5-18 |
| Table 5-10 – Fuel Loading (Cont'd) .....                       | 5-19 |
| Table 5-11 – Fuel Loading .....                                | 5-20 |
| Table 5-12 – Fuel Loading (Cont'd) .....                       | 5-21 |
| Table 5-13 – Required Equipment Table .....                    | 5-22 |

• COPYRIGHT © 2007 BY EAGLE COPTERS MAINTENANCE LTD •

This document is private and confidential and is supplied on the express condition that it is not to be used for any purpose or copied or communicated to any other person without written permission from Eagle Copters Maintenance Ltd.

Unapproved

Revision: **M**

Date: 2026-04-13

## Section 5

### *Weight and Balance Data*

#### **5.1 Introduction**

This section provides information regarding helicopter center of gravity and cockpit and cabin loading. Loading table for pilot and passengers, cargo and fuel are provided. A sample loading problem is provided to aid in flight planning.

#### **5.2 Empty Weight Center of Gravity**

Empty Weight consists of basic helicopter with required equipment, optional equipment kits, transmission and gearbox oils, hydraulic fluid, unusable fuel, undrainable engine oil and fixed ballast. Empty Weight CG shall be adjusted within limits of applicable Empty Weight center of Gravity chart in Instructions for Continued Airworthiness ICA-D212-725. Table 5-13 is an example of a required equipment table for the Eagle Single helicopter. This table may vary depending upon the type of operation.

#### **5.3 Gross Weight Center of Gravity**

It shall be pilot responsibility to ensure helicopter is properly loaded so entire flight is conducted within limits of Gross Weight Center of Gravity Chart in Section 1. GW CG may be calculated from helicopter Actual Weight Record (historical records) and loading tables in this section or in the appropriate Flight Manual Supplements to assure safe loading.

Locations of crew and passenger seats, Cargo compartment and fuel tanks are shown in helicopter station diagram (Figure 5-1).

• COPYRIGHT © 2007 BY EAGLE COPTERS MAINTENANCE LTD •

This document is private and confidential and is supplied on the express condition that it is not to be used for any purpose or copied or communicated to any other person without written permission from Eagle Copters Maintenance Ltd.

## 5.4 Doors Open or Removed

Opening or removing doors results in CG changes. Door configuration shall be symmetrical for both sides of fuselage. Door weights and moments table (Table 5-3) lists weight and moment adjustments which should be made in determining GW and CG when doors are opened or removed.

## 5.5 Cockpit and Cabin Loading

A minimum crew weight of 170 pounds (77.1 kilograms) in cockpit is required. Except for two aft passenger seats, crew and passengers may be loaded in any sequence without exceeding GW CG limits approved for flight.

### Note

*Outboard facing seats should not be occupied unless at least four passengers are seated in forward and/or aft facing seats.*

### 5.5.1 Cabin Deck Loading

Cabin deck cargo loading limit is 100 pounds per square foot (0.048 kilograms per square centimeter).

### **WARNING**

**HELICOPTER CG SHALL BE COMPUTED FOR ALL CARGO/BAGGAGE CONFIGURATIONS BEFORE FLIGHT. REFER TO TABLE 5-2 FOR PERSONNEL WEIGHTS AND MOMENTS IN ENGLISH AND METRIC UNITS.**

• COPYRIGHT © 2007 BY EAGLE COPTERS MAINTENANCE LTD •

This document is private and confidential and is supplied on the express condition that it is not to be used for any purpose or copied or communicated to any other person without written permission from Eagle Copters Maintenance Ltd.

## 5.5.2 Internal Cargo Loading Table

Weights at various arms and their moments are listed in 50 pound increments from 50 pounds through 2000 pounds and in 25 kilogram increments from 25 kilograms through 900 kilograms (Table 5-4).

## 5.6 Cargo Compartment Loading

Cargo compartment is accessible from right side of tailboom and contains approximately 28 cubic feet of space. Cargo compartment has a load limit of 400 pounds (181.4 kilograms) not to exceed 100 pounds per square foot (0.048 kilograms per square centimeter). These are structural limitations only and do not infer that CG will remain within approved limits. When weight is loaded into Cargo compartment the pilot must compute GW CG to ensure that the loading is within approved limits.

### 5.6.1 Cargo Loading

Loading of cargo compartment should be from front to rear. Load shall be secured to tiedown fittings if shifting of load in flight could result in structural damage to cargo compartment or in GW CG limits being exceeded. If cargo is not secured, CG shall be computed with load in most adverse position.

### 5.6.2 Cargo Loading Table

Weights at various arms and their moments are listed in 20 pound increments from 20 pounds through 400 pounds and in 10 kilogram increments from 10 kilograms through 181.4 kilograms (Table 5-8)

## 5.7 Fuel Loading

At beginning of any flight with full fuel on board, helicopter CG will move forward due to the fact that the CG of fuel on board moves forward as it is consumed. This occurs because fuel is consumed from rear (upper) fuel cells first. Maximum forward CG condition of fuel on board occurs when 72.6 U.S. gallons (274.8 liters) remain for helicopter serial numbers prior to 35049 and at 78.5 U.S. gallons (297.1 liters) for helicopter serial numbers 35049 and subsequent. CG then begins to move

• COPYRIGHT © 2007 BY EAGLE COPTERS MAINTENANCE LTD •

This document is private and confidential and is supplied on the express condition that it is not to be used for any purpose or copied or communicated to any other person without written permission from Eagle Copters Maintenance Ltd.

rearward as fuel is consumed from forward (lower) fuel cells. With normal crew and passenger loading, GW CG should remain within limits at any fuel quantity.

Fuel quantities are listed with moments in 10 gallon increments from 10 gallons through 216.8 gallons and in 40 liter increments from 40 liters through 820.7 liters for helicopter serial numbers prior to 35049 (Table 5-9 and 5-10).

Fuel quantities are listed with moments in 10 gallon increments from 10 gallons through 218.6 gallons and in 40 liter increments from 40 liters through 827.4 liters for helicopter serial numbers 35049 and subsequent (Table 5-11 and 5-12).

### 5.7.1 Computation of CG

A sample problem is presented showing calculation of takeoff and landing weights and CG locations for two typical loading conditions.

### 5.7.2 Sample Loading Problem

The helicopter (serial number 35050) is chartered to transport nine passengers (170 Lbs. each) and 180 pounds of baggage for a trip that will require approximately 158.6 gallons (600.3 liters) of fuel. The pilot also weighs 170 pounds (78 kilograms). The helicopter will have full fuel (Jet A) for takeoff. Determine extreme CG conditions for the trip.

From GW CG charts in Section 1, it can be determined that CG is within limits for the flight and that the loading of passengers in the five man and four man seats will be satisfactory.

• COPYRIGHT © 2007 BY EAGLE COPTERS MAINTENANCE LTD •

This document is private and confidential and is supplied on the express condition that it is not to be used for any purpose or copied or communicated to any other person without written permission from Eagle Copters Maintenance Ltd.

Table 5-1 – Sample Loading Problem (English Units)  
Helicopter serial numbers 35049 and subsequent

|                                       |                                       | Weight<br>(Lbs) | CG<br>(Inch) | Moment<br>(In-Lbs) |
|---------------------------------------|---------------------------------------|-----------------|--------------|--------------------|
| Basic<br>Operating<br>Weight          | Licensed Empty Weight                 | 5764.5          | 145.3        | 837508             |
|                                       | + Oil                                 | 24.0            | 175.2        | 4146               |
|                                       | + Pilot*                              | 170.0           | 47.0         | 7990               |
| Payload                               | + Passengers (5 man seat)*            | 850.0           | 117.0        | 99450              |
|                                       | + Passengers (4 man seat)*            | 680.0           | 87.0         | 59160              |
|                                       | + Cargo Compartment*                  | 180.0           | 261.0        | 46980              |
|                                       | Basic Operating Weight + Payload      | 7668.5          | 137.6        | 1055234            |
| Takeoff<br>Conditions                 | Basic Operating Weight + Payload      | 7668.5          | 137.6        | 1055234            |
|                                       | + Takeoff Fuel (216.8 gallons Jet A)* | 1486.0          | 152.7        | 226837             |
|                                       | Takeoff Weight, CG and Moment         | 9154.5          | 140.0        | 1282071            |
| Most Critical<br>FWD CG<br>Conditions | Basic Operating Weight + Payload      | 7668.5          | 137.6        | 1055234            |
|                                       | + Critical Fuel (72.6 gallons Jet A)* | 534.0           | 127.3        | 67953              |
|                                       | Critical Weight, CG and Moment        | 8202.5          | 136.9        | 1123187            |
| Landing<br>Conditions                 | Basic Operating Weight + Payload      | 7668.5          | 137.6        | 1055234            |
|                                       | + Landing Fuel (60 gallons Jet A)*    | 408.0           | 129.9        | 52999              |
|                                       | Landing Weight, CG and Moment         | 8076.5          | 137.2        | 1108233            |

(\* Information obtained from loading charts)

• COPYRIGHT © 2007 BY EAGLE COPTERS MAINTENANCE LTD •

This document is private and confidential and is supplied on the express condition that it is not to be used for any purpose or copied or communicated to any other person without written permission from Eagle Copters Maintenance Ltd.

Table 5-2 – Sample Loading Problem (Metric Units)  
Helicopter serial numbers 35049 and subsequent

|                                       |   | Weight<br>(Kg)                        | CG<br>(MM) | Moment<br>(Kg-<br>MM/100) |          |
|---------------------------------------|---|---------------------------------------|------------|---------------------------|----------|
| Basic<br>Operating<br>Weight          | { | Licensed Empty Weight                 | 2614.8     | 3690.4                    | 96485.7  |
|                                       |   | + Oil                                 | 11.1       | 4298.3                    | 477.1    |
|                                       |   | + Pilot*                              | 77.1       | 1194.0                    | 920.6    |
| Payload                               | { | + Passengers (5 man seat)*            | 385.6      | 2972.0                    | 11460.0  |
|                                       |   | + Passengers (4 man seat)*            | 308.4      | 2210.0                    | 6815.6   |
|                                       |   | + Cargo Compartment*                  | 81.6       | 6629.4                    | 5409.6   |
|                                       |   | Basic Operating Weight + Payload      | 3478.6     | 3495.0                    | 121578.6 |
| Takeoff<br>Conditions                 | { | Basic Operating Weight + Payload      | 3478.6     | 3495.0                    | 121578.6 |
|                                       |   | + Takeoff Fuel (820.7 liters Jet A)*  | 674.3      | 3876.0                    | 26135.9  |
|                                       |   | Takeoff Weight, CG and Moment         | 4152.9     | 3556.9                    | 147714.5 |
| Most Critical<br>FWD CG<br>Conditions | { | Basic Operating Weight + Payload      | 3478.6     | 3495.0                    | 121578.6 |
|                                       |   | + Critical Fuel (274.8 liters Jet A)* | 242.1      | 3233.0                    | 7827.1   |
|                                       |   | Critical Weight, CG and Moment        | 3720.7     | 3478.0                    | 129405.7 |
| Landing<br>Conditions                 | { | Basic Operating Weight + Payload      | 3478.6     | 3495.0                    | 121578.6 |
|                                       |   | + Landing Fuel (227.1 liters Jet A)*  | 185.1      | 3299.5                    | 6107.3   |
|                                       |   | Landing Weight, CG and Moment         | 3663.7     | 3485.2                    | 127685.9 |

(\* Information obtained from loading charts)

• COPYRIGHT © 2007 BY EAGLE COPTERS MAINTENANCE LTD •

This document is private and confidential and is supplied on the express condition that it is not to be used for any purpose or copied or communicated to any other person without written permission from Eagle Copters Maintenance Ltd.

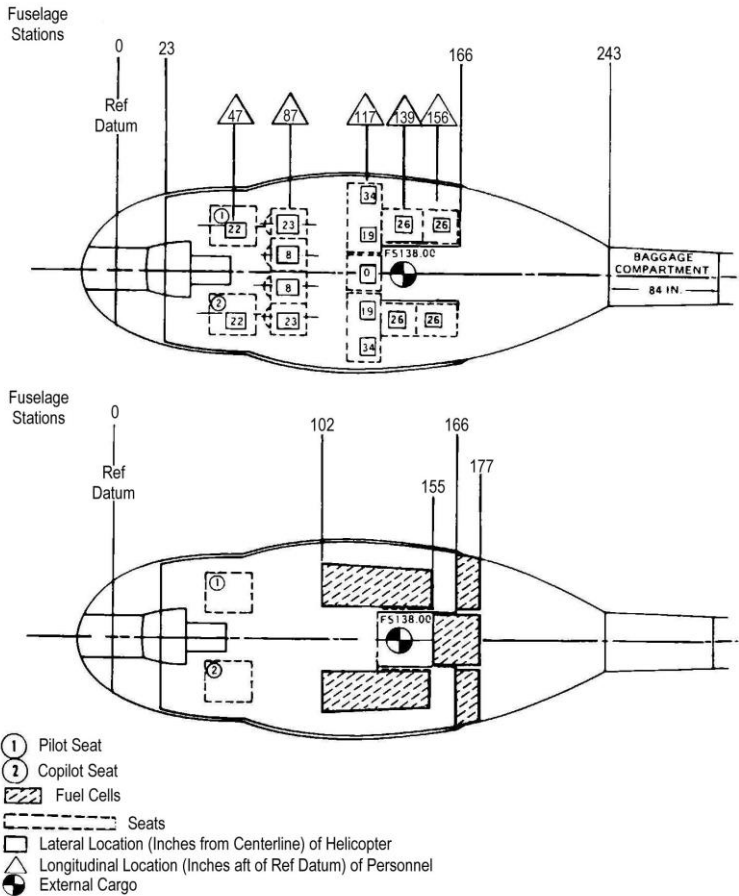

Figure 5-1 – Helicopter Station Diagram

• COPYRIGHT © 2007 BY EAGLE COPTERS MAINTENANCE LTD •

This document is private and confidential and is supplied on the express condition that it is not to be used for any purpose or copied or communicated to any other person without written permission from Eagle Copters Maintenance Ltd.

Table 5-3 – Door Weights and Moments

| English                      |                           |                   |                           |
|------------------------------|---------------------------|-------------------|---------------------------|
| Door Configuration           | Weight Change (Pounds)    | Arm (Inches)      | Moment Change (In-Lb)     |
| Both crew doors removed      | -39.0                     | 46.2              | -1802                     |
| Both hinged panels removed   | -20.4                     | 85.0              | -1734                     |
| Both sliding doors removed   | -90.4                     | 130.0             | -11752                    |
| Both sliding doors full open | 0                         | 202.0             | +6509                     |
| Metric                       |                           |                   |                           |
| Door Configuration           | Weight Change (kilograms) | Arm (millimeters) | Moment Change (Kg-mm/100) |
| Both crew doors removed      | -17.7                     | 1173              | -207.6                    |
| Both hinged panels removed   | -9.3                      | 2159              | -200.8                    |
| Both sliding doors removed   | -41.0                     | 3302              | -1353.8                   |
| Both sliding doors full open | 0                         | 5131              | +749.9                    |

• COPYRIGHT © 2007 BY EAGLE COPTERS MAINTENANCE LTD •

This document is private and confidential and is supplied on the express condition that it is not to be used for any purpose or copied or communicated to any other person without written permission from Eagle Copters Maintenance Ltd.

Unapproved

Revision: **M**

Date: 2026-04-13

Table 5-4 – Crew and passenger table of moments

| Crew and Passenger Table of Moments |                           |   |  |                           |                 |                       |                     |  |  |
|-------------------------------------|---------------------------|---|--|---------------------------|-----------------|-----------------------|---------------------|--|--|
| Weight (Pounds)                     | Pilot And Co-pilot* FS 47 | Passenger (4 – Man Seat Facing Aft) FS 87 | Passenger (5 – man Seat Facing Fwd) FS 117 | Passenger Facing Outboard |                 | Litter Patient        |                     |  |  |
|                                     |                           |   |  | Fwd Seat FS 139           | Aft Seat FS 156 | Lateral Loaded FS 117 | Long. Loaded FS 120 |  |  |
| 100                                 | 4700                      | 8700                                      | 11700                                      | 13900                     | 15600           | 11700                 | 12000               |  |  |
| 110                                 | 5170                      | 9570                                      | 12870                                      | 15290                     | 17160           | 12870                 | 13200               |  |  |
| 120                                 | 5640                      | 10440                                     | 14040                                      | 16680                     | 18720           | 14040                 | 14400               |  |  |
| 130                                 | 6110                      | 11310                                     | 15210                                      | 18070                     | 20280           | 15210                 | 15600               |  |  |
| 140                                 | 6580                      | 12180                                     | 16380                                      | 19460                     | 21840           | 16380                 | 16800               |  |  |
| 150                                 | 7050                      | 13050                                     | 17550                                      | 20850                     | 23400           | 17550                 | 18000               |  |  |
| 160                                 | 7520                      | 13920                                     | 18720                                      | 22240                     | 24960           | 18720                 | 19200               |  |  |
| 170                                 | 7990                      | 14790                                     | 19890                                      | 23630                     | 26520           | 19890                 | 20400               |  |  |
| 180                                 | 8460                      | 15660                                     | 21060                                      | 25020                     | 28080           | 21060                 | 21600               |  |  |
| 190                                 | 8930                      | 16530                                     | 22230                                      | 26410                     | 29640           | 22230                 | 22800               |  |  |
| 200                                 | 9400                      | 17400                                     | 23400                                      | 27800                     | 31200           | 23400                 | 24000               |  |  |
| 210                                 | 9870                      | 18270                                     | 24570                                      | 29190                     | 32760           | 24570                 | 25200               |  |  |
| 220                                 | 10340                     | 19140                                     | 25740                                      | 30580                     | 34320           | 25740                 | 26400               |  |  |

\* Left Forward Seat

• COPYRIGHT © 2007 BY EAGLE COPTERS MAINTENANCE LTD •

This document is private and confidential and is supplied on the express condition that it is not to be used for any purpose or copied or communicated to any other person without written permission from Eagle Copters Maintenance Ltd.

Table 5-5 – Crew and Passenger Table of Moments (Cont'd)

| Crew and Passenger Table of Moments (Metric) (kg* mm/100) |                                      |  |  |                              |                        |                              |                            |  |  |
|---|--------------------------------------|--|--|------------------------------|------------------------|------------------------------|----------------------------|--|--|
| Weight<br>(Kilograms)                                     | Pilot<br>And<br>Co-pilot*<br>FS 1194 | Passenger<br>(4 – Man<br>Facing<br>Aft)<br>FS 2210 | Passenger<br>(5 – man<br>Facing<br>Fwd)<br>FS 2972 | Passenger Facing<br>Outboard |                        | Litter Patient               |                            |  |  |
|   |                                      |  |  | Fwd<br>Seat<br>FS 3531       | Aft<br>Seat<br>FS 3962 | Lateral<br>Loaded<br>FS 2972 | Long.<br>Loaded<br>FS 3048 |  |  |
| 45  | 537.3                                | 994.5  | 1337.4   | 1589.0                       | 1782.9                 | 1337.4                       | 1371.6                     |  |  |
| 50  | 597.0                                | 1105.0   | 1486.0   | 1765.5                       | 1981.0                 | 1486.0                       | 1524.0                     |  |  |
| 55  | 656.7                                | 1215.5   | 1634.6   | 1942.1                       | 2179.1                 | 1634.6                       | 1676.4                     |  |  |
| 60  | 716.4                                | 1326.0   | 1783.2   | 2118.6                       | 2377.2                 | 1783.2                       | 1828.8                     |  |  |
| 65  | 776.1                                | 1436.5   | 1931.8   | 2295.2                       | 2575.3                 | 1931.8                       | 1981.2                     |  |  |
| 70  | 835.8                                | 1547.0   | 2080.4   | 2471.7                       | 2773.4                 | 2080.4                       | 2133.6                     |  |  |
| 75  | 895.5                                | 1657.5   | 2229.0   | 2648.3                       | 2971.5                 | 2229.0                       | 2286.0                     |  |  |
| 80  | 955.2                                | 1768.0   | 2377.6   | 2824.8                       | 3169.6                 | 2377.6                       | 2438.4                     |  |  |
| 85  | 1014.9                               | 1878.5   | 2526.2   | 3001.4                       | 3367.7                 | 2526.2                       | 2590.8                     |  |  |
| 90  | 1074.6                               | 1989.0   | 2674.8   | 3177.9                       | 3565.8                 | 2674.8                       | 2743.2                     |  |  |
| 95  | 1134.3                               | 2099.5   | 2823.4   | 3354.5                       | 3763.9                 | 2823.4                       | 2895.6                     |  |  |
| * Left Forward Seat                                       |                                      |  |  |                              |                        |                              |                            |  |  |

• COPYRIGHT © 2007 BY EAGLE COPTERS MAINTENANCE LTD •

This document is private and confidential and is supplied on the express condition that it is not to be used for any purpose or copied or communicated to any other person without written permission from Eagle Copters Maintenance Ltd.



Table 5-6 – Internal Cargo Loading

| Cargo Weight (Pounds) | Internal Cargo Loading Table (English) |        |        |        |        |        |
|-----------------------|--|--------|--------|--------|--------|--------|
|                       | Cargo Center of Gravity (FS)           |        |        |        |        |        |
|                       | 75                                     | 90     | 105    | 120    | 135    | 150    |
|                       | Cargo Moment (In-Lb)                   |        |        |        |        |        |
| 50                    | 3750                                   | 4500   | 5250   | 6000   | 6750   | 7500   |
| 100                   | 7500                                   | 9000   | 10500  | 12000  | 13500  | 15000  |
| 150                   | 11250                                  | 13500  | 15750  | 18000  | 20250  | 22500  |
| 200                   | 15000                                  | 18000  | 21000  | 24000  | 27000  | 30000  |
| 250                   | 18750                                  | 22500  | 26250  | 30000  | 33750  | 37500  |
| 300                   | 22500                                  | 27000  | 31500  | 36000  | 40500  | 45000  |
| 350                   | 26250                                  | 31500  | 36750  | 42000  | 47250  | 52500  |
| 400                   | 30000                                  | 36000  | 42000  | 48000  | 54000  | 60000  |
| 450                   | 33750                                  | 40500  | 47250  | 54000  | 60750  | 67500  |
| 500                   | 37500                                  | 45000  | 52500  | 60000  | 67500  | 75000  |
| 550                   | 41250                                  | 49500  | 57750  | 66000  | 74250  | 82500  |
| 600                   | 45000                                  | 54000  | 63000  | 72000  | 81000  | 90000  |
| 650                   | 48750                                  | 58500  | 68250  | 78000  | 87750  | 97500  |
| 700                   | 52500                                  | 63000  | 73500  | 84000  | 94500  | 105000 |
| 750                   | 56250                                  | 67500  | 78750  | 90000  | 101250 | 112500 |
| 800                   | 60000                                  | 72000  | 84000  | 96000  | 108000 | 120000 |
| 850                   | 63750                                  | 76500  | 89250  | 102000 | 114750 | 127500 |
| 900                   | 67500                                  | 81000  | 94500  | 108000 | 121500 | 135000 |
| 950                   | 71250                                  | 85500  | 99750  | 114000 | 128250 | 142500 |
| 1000                  | 75000                                  | 90000  | 105000 | 120000 | 135000 | 150000 |
| 1050                  | 78750                                  | 94500  | 110250 | 126000 | 141750 | 157500 |
| 1100                  | 82500                                  | 99000  | 115500 | 132000 | 148500 | 165000 |
| 1150                  | 86250                                  | 103500 | 102750 | 138000 | 155250 | 172500 |
| 1200                  | 90000                                  | 108000 | 126000 | 144000 | 162000 | 180000 |
| 1250                  | 93750                                  | 112500 | 131250 | 150000 | 168750 | 187500 |
| 1300                  | 97500                                  | 117000 | 136500 | 156000 | 175500 | 195000 |

• COPYRIGHT © 2007 BY EAGLE COPTERS MAINTENANCE LTD •

This document is private and confidential and is supplied on the express condition that it is not to be used for any purpose or copied or communicated to any other person without written permission from Eagle Copters Maintenance Ltd.

| Cargo Weight (Pounds) | Internal Cargo Loading Table (English) |        |        |        |        |        |
|-----------------------|--|--------|--------|--------|--------|--------|
|                       | Cargo Center of Gravity (FS)           |        |        |        |        |        |
|                       | 75                                     | 90     | 105    | 120    | 135    | 150    |
|                       | Cargo Moment (In-Lb)                   |        |        |        |        |        |
| 1350                  | 101250                                 | 121500 | 141750 | 162000 | 182250 | 202500 |
| 1400                  | 105000                                 | 126000 | 147000 | 168000 | 189000 | 210000 |
| 1450                  | 108750                                 | 130500 | 152250 | 174000 | 195750 | 217500 |
| 1500                  | 112500                                 | 135000 | 157500 | 180000 | 202500 | 225000 |
| 1550                  | 116250                                 | 139500 | 162750 | 186000 | 209250 | 232500 |
| 1600                  | 120000                                 | 144000 | 168000 | 192000 | 216000 | 240000 |
| 1650                  | 123750                                 | 148500 | 173250 | 198000 | 222750 | 247500 |
| 1700                  | 127500                                 | 153000 | 178500 | 204000 | 229500 | 255000 |
| 1750                  | 131250                                 | 157500 | 183750 | 210000 | 236250 | 262500 |
| 1800                  | 135000                                 | 162000 | 189000 | 216000 | 243000 | 270000 |
| 1850                  | 138750                                 | 166500 | 194250 | 222000 | 249750 | 277500 |
| 1900                  | 142500                                 | 171000 | 199500 | 228000 | 256500 | 285000 |
| 1950                  | 146250                                 | 175500 | 204750 | 234000 | 263250 | 292500 |
| 2000                  | 150000                                 | 180000 | 210000 | 240000 | 270000 | 300000 |

• COPYRIGHT © 2007 BY EAGLE COPTERS MAINTENANCE LTD •

This document is private and confidential and is supplied on the express condition that it is not to be used for any purpose or copied or communicated to any other person without written permission from Eagle Copters Maintenance Ltd.

Unapproved

Revision: **M**

Date: 2026-04-13

Table 5-7 – Internal Cargo Loading (Cont'd)

| Cargo Weight (Kg) | Internal Cargo Loading Table (Metric) |         |         |         |         |         |
|-------------------|---------------------------------------|---------|---------|---------|---------|---------|
|                   | Cargo Center of Gravity (MM)          |         |         |         |         |         |
|                   | 1905                                  | 2286    | 2667    | 3048    | 3429    | 3810    |
|                   | Cargo Moment (Kg-MM/100)              |         |         |         |         |         |
| 25                | 476.3                                 | 571.5   | 666.8   | 762.0   | 857.3   | 952.5   |
| 50                | 952.5                                 | 1143.0  | 1333.5  | 1524.0  | 1714.5  | 1905.0  |
| 75                | 1428.8                                | 1714.5  | 2000.3  | 2286.0  | 2571.8  | 2857.5  |
| 100               | 1905.0                                | 2286.0  | 2667.0  | 3048.0  | 3429.0  | 3810.0  |
| 125               | 2381.3                                | 2857.5  | 3333.8  | 3810.0  | 4286.3  | 4762.5  |
| 150               | 2857.5                                | 3429.0  | 4000.5  | 4572.0  | 5143.5  | 5715.0  |
| 175               | 3333.8                                | 4000.5  | 4667.3  | 5334.0  | 6000.8  | 6667.5  |
| 200               | 3810.0                                | 4272.0  | 5334.0  | 6096.0  | 6858.0  | 7620.0  |
| 225               | 4286.3                                | 5143.5  | 6000.8  | 6858.0  | 7715.3  | 8572.5  |
| 250               | 4762.5                                | 5715.0  | 6667.5  | 7620.0  | 8572.5  | 9525.0  |
| 275               | 5238.8                                | 6286.5  | 7334.3  | 8382.0  | 9429.8  | 10477.5 |
| 300               | 5715.0                                | 6858.0  | 8001.0  | 9144.0  | 10287.0 | 11430.0 |
| 325               | 6191.3                                | 7429.5  | 8667.8  | 9906.0  | 11144.3 | 12382.5 |
| 350               | 6667.5                                | 8001.0  | 9334.5  | 10668.0 | 12001.5 | 13335.0 |
| 375               | 7143.8                                | 8572.5  | 10001.3 | 11430.0 | 12858.8 | 14287.5 |
| 400               | 7620.0                                | 9144.0  | 10668.0 | 12192.0 | 13716.0 | 15240.0 |
| 425               | 8096.3                                | 9715.5  | 11334.8 | 12954.0 | 14573.3 | 16192.5 |
| 450               | 8572.5                                | 10287.0 | 12001.5 | 13716.0 | 15430.5 | 17145.0 |
| 475               | 9048.8                                | 10858.5 | 12668.3 | 14478.0 | 16287.8 | 18097.5 |
| 500               | 9525.0                                | 11430.0 | 13335.0 | 15240.0 | 17145.0 | 19050.0 |
| 525               | 10001.3                               | 12001.5 | 14001.8 | 16002.0 | 18002.3 | 20002.5 |
| 550               | 10477.5                               | 12573.0 | 14668.5 | 16764.0 | 18859.5 | 20955.0 |
| 575               | 10953.8                               | 13144.5 | 15335.3 | 17526.0 | 19716.8 | 21907.5 |
| 600               | 11430.0                               | 13716.0 | 16002.0 | 18288.0 | 20574.0 | 22860.0 |
| 625               | 11906.3                               | 14287.5 | 16668.8 | 19050.0 | 21431.3 | 23812.5 |
| 650               | 12382.5                               | 14859.0 | 17335.5 | 19812.0 | 22288.5 | 24765.0 |
| 675               | 12858.8                               | 15430.5 | 18002.3 | 20574.0 | 23145.8 | 25717.5 |

• COPYRIGHT © 2007 BY EAGLE COPTERS MAINTENANCE LTD •

This document is private and confidential and is supplied on the express condition that it is not to be used for any purpose or copied or communicated to any other person without written permission from Eagle Copters Maintenance Ltd.

| Cargo Weight (Kg) | Internal Cargo Loading Table (Metric) |         |         |         |         |         |
|-------------------|---------------------------------------|---------|---------|---------|---------|---------|
|                   | Cargo Center of Gravity (MM)          |         |         |         |         |         |
|                   | 1905                                  | 2286    | 2667    | 3048    | 3429    | 3810    |
|                   | Cargo Moment (Kg-MM/100)              |         |         |         |         |         |
| 700               | 13335.0                               | 16002.0 | 18669.0 | 21336.0 | 24003.0 | 26670.0 |
| 725               | 13811.3                               | 16573.5 | 19335.8 | 22098.0 | 24860.3 | 27622.5 |
| 750               | 14287.5                               | 17145.0 | 20002.5 | 22860.0 | 25717.5 | 28575.0 |
| 775               | 14763.8                               | 17716.5 | 20669.3 | 23622.0 | 26574.8 | 29527.5 |
| 800               | 15240.0                               | 18288.0 | 21336.0 | 24384.0 | 27432.0 | 30480.0 |
| 825               | 15716.3                               | 18859.5 | 22002.8 | 25146.0 | 28289.3 | 31432.5 |
| 850               | 16192.5                               | 19431.0 | 22669.5 | 25908.0 | 29146.5 | 32385.0 |
| 875               | 16668.8                               | 20002.5 | 23336.3 | 26670.0 | 30003.8 | 33337.5 |
| 900               | 17145.0                               | 20574.0 | 24003.0 | 27432.0 | 30861.0 | 34290.0 |

• COPYRIGHT © 2007 BY EAGLE COPTERS MAINTENANCE LTD •

This document is private and confidential and is supplied on the express condition that it is not to be used for any purpose or copied or communicated to any other person without written permission from Eagle Copters Maintenance Ltd.

Unapproved

Revision: **M**

Date: 2026-04-13

Table 5-8 – Cargo Loading

| Cargo Loading Table (English)              |                 |        |             |                 |        |
|--|-----------------|--------|-------------|-----------------|--------|
| Load Cargo from forward end of compartment |                 |        |             |                 |        |
| 400 Pound Maximum                          |                 |        |             |                 |        |
| Weight (Lb)                                | Approx. CG (FS) | Moment | Weight (Lb) | Approx. CG (FS) | Moment |
| 20   | 245             | 4900   | 220         | 265             | 58300  |
| 40   | 247             | 9880   | 240         | 267             | 64080  |
| 60   | 249             | 14940  | 260         | 269             | 69940  |
| 80   | 251             | 20080  | 280         | 271             | 75880  |
| 100  | 253             | 25300  | 300         | 273             | 81900  |
| 120  | 255             | 30600  | 320         | 275             | 88000  |
| 140  | 257             | 35980  | 340         | 277             | 94180  |
| 160  | 259             | 41440  | 360         | 279             | 100440 |
| 180  | 261             | 46980  | 380         | 281             | 106780 |
| 200  | 263             | 52600  | 400         | 283             | 113200 |

| Cargo Loading Table (Metric)               |                 |                    |             |                 |                    |
|--|-----------------|--------------------|-------------|-----------------|--------------------|
| Load Cargo from forward end of compartment |                 |                    |             |                 |                    |
| 181.4 Kilograms Maximum                    |                 |                    |             |                 |                    |
| Weight (Kg)                                | Approx. CG (MM) | Moment (Kg-MM/100) | Weight (Kg) | Approx. CG (MM) | Moment (Kg-MM/100) |
| 10   | 6228            | 622.8              | 110         | 6789            | 7467.9             |
| 20   | 6284            | 1256.8             | 120         | 6845            | 8214.0             |
| 30   | 6340            | 1902.0             | 130         | 6901            | 8971.3             |
| 40   | 6396            | 2558.4             | 140         | 6957            | 9739.8             |
| 50   | 6452            | 3226.0             | 150         | 7013            | 10519.5            |
| 60   | 6507            | 3904.2             | 160         | 7069            | 11310.4            |
| 70   | 6563            | 4594.1             | 170         | 7125            | 12112.5            |
| 80   | 6619            | 5295.2             | 180         | 7181            | 12925.8            |
| 90   | 6675            | 6007.5             | 181.4       | 7188            | 13039.0            |
| 100  | 6734            | 6734.0             |             |                 |                    |

• COPYRIGHT © 2007 BY EAGLE COPTERS MAINTENANCE LTD •

This document is private and confidential and is supplied on the express condition that it is not to be used for any purpose or copied or communicated to any other person without written permission from Eagle Copters Maintenance Ltd.



Table 5-9 – Fuel Loading  
Helicopter serial numbers prior to 35049  
English

| ASTM D-1655 Type A, A-1, JP-5, and JP-8<br>(6.8 Lbs/Gal) |                |            |                   | ASTM D-1655 Type B and JP-4<br>(6.5 Lbs/Gal) |                |            |                   |
|--|----------------|------------|-------------------|--|----------------|------------|-------------------|
| Quantity<br>(US Gal)                                     | Weight<br>(Lb) | CG<br>(In) | Moment<br>(In-Lb) | Quantity<br>(US Gal)                         | Weight<br>(Lb) | CG<br>(In) | Moment<br>(In-Lb) |
| 10   | 68             | 143.6      | 9765              | 10   | 65             | 143.6      | 9334              |
| 20   | 136            | 143.6      | 19530             | 20   | 130            | 143.6      | 18668             |
| 30   | 204            | 140.2      | 28601             | 30   | 195            | 140.2      | 27339             |
| 40   | 272            | 134.8      | 36666             | 40   | 260            | 134.8      | 35048             |
| 50   | 340            | 131.6      | 44744             | 50   | 325            | 131.6      | 42770             |
| 60   | 408            | 129.4      | 52795             | 60   | 390            | 129.4      | 50466             |
| 70   | 476            | 127.9      | 60880             | 70   | 455            | 127.9      | 58195             |
| *72.6  | 494            | 127.6      | 63034             | *72.6  | 472            | 127.6      | 60227             |
| 80   | 544            | 128.3      | 69795             | 80   | 520            | 128.3      | 66716             |
| 90   | 612            | 130.6      | 79927             | 90   | 585            | 130.6      | 76401             |
| 100  | 680            | 134.6      | 91528             | 100  | 650            | 134.6      | 87490             |
| 110  | 748            | 137.8      | 103074            | 110  | 715            | 137.8      | 98527             |
| 120  | 816            | 140.4      | 114566            | 120  | 780            | 140.4      | 109512            |
| 130  | 884            | 142.6      | 126058            | 130  | 845            | 142.6      | 120497            |
| 140  | 952            | 144.6      | 137659            | 140  | 910            | 144.6      | 131586            |
| 150  | 1020           | 146.1      | 149022            | 150  | 975            | 146.1      | 142448            |
| 160  | 1088           | 147.6      | 160589            | 160  | 1040           | 147.6      | 153504            |
| 170  | 1156           | 148.8      | 172013            | 170  | 1105           | 148.8      | 164424            |
| 180  | 1224           | 149.9      | 183478            | 180  | 1170           | 149.9      | 175383            |
| 190  | 1292           | 150.9      | 194963            | 190  | 1235           | 150.9      | 186362            |
| 200  | 1360           | 151.9      | 206584            | 200  | 1300           | 151.9      | 197470            |
| 210  | 1428           | 152.7      | 218056            | 210  | 1365           | 152.7      | 208436            |
| **216.8  | 1474           | 153.3      | 225964            | **216.8                                      | 1409           | 153.3      | 216000            |

\* Most critical fuel amount for most forward flight condition.

\*\* Most critical fuel amount for most aft flight condition.

Note: All data above represents usable fuel based on nominal density at 15°C (59°F)

• COPYRIGHT © 2007 BY EAGLE COPTERS MAINTENANCE LTD •

This document is private and confidential and is supplied on the express condition that it is not to be used for any purpose or copied or communicated to any other person without written permission from Eagle Copters Maintenance Ltd.

Unapproved

Revision: **M**

Date: 2026-04-13



Table 5-10 – Fuel Loading (Cont'd)  
Helicopter serial numbers prior to 35049

| Metric   |                |            |                           | Metric                                      |                |            |                           |
|--|----------------|------------|---------------------------|---|----------------|------------|---------------------------|
| ASTM D-1655 Type A, A-1, JP-5,<br>and JP-8<br>(0.815 Kg/L) |                |            |                           | ASTM D-1655 Type B and JP-4<br>(0.779 Kg/L) |                |            |                           |
| Quantity<br>(Liters)                                       | Weight<br>(Kg) | CG<br>(MM) | Moment<br>(Kg-<br>MM/100) | Quantity<br>(Liters)                        | Weight<br>(Kg) | CG<br>(MM) | Moment<br>(Kg-<br>MM/100) |
| 40   | 32.6           | 3647       | 1188.9                    | 40  | 31.2           | 3647       | 1137.9                    |
| 80   | 65.2           | 3647       | 2377.8                    | 80  | 62.3           | 3647       | 2272.1                    |
| 120  | 97.8           | 3541       | 3463.1                    | 120   | 93.5           | 3541       | 3310.8                    |
| 160  | 130.4          | 3399       | 4432.3                    | 160   | 124.6          | 3399       | 4235.2                    |
| 200  | 163.0          | 3322       | 5414.9                    | 200   | 155.8          | 3322       | 5175.7                    |
| 240  | 195.6          | 3272       | 6400.0                    | 240   | 187.0          | 3272       | 6118.6                    |
| *274.8   | 224.0          | 3241       | 7259.8                    | *274.8                                      | 214.1          | 3241       | 6939.0                    |
| 280  | 228.2          | 3246       | 7407.4                    | 280   | 218.1          | 3246       | 7079.5                    |
| 320  | 260.8          | 3277       | 8546.4                    | 320   | 249.3          | 3277       | 8169.6                    |
| 360  | 293.4          | 3368       | 9881.7                    | 360   | 280.4          | 3368       | 9443.9                    |
| 400  | 326.0          | 3470       | 11312.2                   | 400   | 311.6          | 3470       | 10812.5                   |
| 440  | 358.6          | 3541       | 12698.0                   | 440   | 342.8          | 3541       | 12138.5                   |
| 480  | 391.2          | 3609       | 14118.4                   | 480   | 373.9          | 3609       | 13494.1                   |
| 520  | 423.8          | 3665       | 15532.3                   | 520   | 405.1          | 3665       | 14846.9                   |
| 560  | 456.4          | 3708       | 16923.3                   | 560   | 436.2          | 3708       | 16174.3                   |
| 600  | 489.0          | 3744       | 18308.2                   | 600   | 467.4          | 3744       | 17499.5                   |
| 640  | 521.6          | 3777       | 19700.8                   | 640   | 498.6          | 3777       | 18832.1                   |
| 680  | 554.2          | 3805       | 21087.3                   | 680   | 529.7          | 3805       | 20155.1                   |
| 720  | 586.8          | 3833       | 22492.0                   | 720   | 560.9          | 3833       | 21499.3                   |
| 760  | 619.4          | 3858       | 23896.5                   | 760   | 592.0          | 3858       | 22839.4                   |
| 800  | 652.0          | 3884       | 25323.7                   | 800   | 623.2          | 3884       | 24205.1                   |
| **820.7  | 668.9          | 3894       | 26047.0                   | **820.7                                     | 639.3          | 3894       | 24894.3                   |

\* Most critical fuel amount for most forward flight condition.  
 \*\* Most critical fuel amount for most aft flight condition.

Note: All data above represents usable fuel based on nominal density at 15°C (59°F)

• COPYRIGHT © 2007 BY EAGLE COPTERS MAINTENANCE LTD •

This document is private and confidential and is supplied on the express condition that it is not to be used for any purpose or copied or communicated to any other person without written permission from Eagle Copters Maintenance Ltd.



Table 5-11 – Fuel Loading  
Helicopter serial numbers 35049 and subsequent  
English

| ASTM D-1655 Type A, A-1, JP-5, and JP-8<br>(6.8 Lbs/Gal) |                |            |                   | ASTM D-1655 Type B and JP-4<br>(6.5 Lbs/Gal) |                |            |                   |
|--|----------------|------------|-------------------|--|----------------|------------|-------------------|
| Quantity<br>(US Gal)                                     | Weight<br>(Lb) | CG<br>(In) | Moment<br>(In-Lb) | Quantity<br>(US Gal)                         | Weight<br>(Lb) | CG<br>(In) | Moment<br>(In-Lb) |
| 10   | 68             | 143.9      | 9785              | 10   | 65             | 143.9      | 9354              |
| 20   | 136            | 144.0      | 19584             | 20   | 130            | 144.0      | 18720             |
| 30   | 204            | 141.6      | 28886             | 30   | 195            | 141.6      | 27612             |
| 40   | 272            | 135.7      | 36910             | 40   | 260            | 135.7      | 35282             |
| 50   | 340            | 132.2      | 44948             | 50   | 325            | 132.2      | 42965             |
| 60   | 408            | 129.9      | 52999             | 60   | 390            | 129.9      | 50661             |
| 70   | 476            | 128.2      | 61023             | 70   | 455            | 128.2      | 58331             |
| *78.5  | 534            | 127.3      | 67953             | *78.5  | 510            | 127.3      | 64955             |
| 80   | 544            | 127.4      | 69306             | 80   | 520            | 127.4      | 66248             |
| 90   | 612            | 129.5      | 79254             | 90   | 585            | 129.5      | 75758             |
| 100  | 680            | 133.4      | 90712             | 100  | 650            | 133.4      | 86710             |
| 110  | 748            | 136.7      | 102252            | 110  | 715            | 136.7      | 97741             |
| 120  | 816            | 139.3      | 113669            | 120  | 780            | 139.3      | 108654            |
| 130  | 884            | 141.7      | 125263            | 130  | 845            | 141.7      | 119737            |
| 140  | 952            | 143.6      | 136707            | 140  | 910            | 143.6      | 130676            |
| 150  | 1020           | 145.2      | 148104            | 150  | 975            | 145.2      | 141570            |
| 160  | 1088           | 146.8      | 159718            | 160  | 1040           | 146.8      | 152672            |
| 170  | 1156           | 148.1      | 171204            | 170  | 1105           | 148.1      | 163651            |
| 180  | 1224           | 149.3      | 182743            | 180  | 1170           | 149.3      | 174681            |
| 190  | 1292           | 150.3      | 194188            | 190  | 1235           | 150.3      | 185621            |
| 200  | 1360           | 151.3      | 205768            | 200  | 1300           | 151.3      | 196690            |
| 210  | 1428           | 152.1      | 217199            | 210  | 1365           | 152.1      | 207617            |
| 218.6  | 1486           | 152.6      | 226837            | 218.6  | 1421           | 152.6      | 216829            |

\* Most critical fuel amount for most forward flight condition.

Note: All data above represents usable fuel based on nominal density at 15°C (59°F)

• COPYRIGHT © 2007 BY EAGLE COPTERS MAINTENANCE LTD •

This document is private and confidential and is supplied on the express condition that it is not to be used for any purpose or copied or communicated to any other person without written permission from Eagle Copters Maintenance Ltd.

Unapproved

Revision: M

Date: 2026-04-13

Table 5-12 – Fuel Loading (Cont'd)  
Helicopter serial numbers 35049 and subsequent

| Metric   |                |            |                           | Metric                                      |                |            |                           |
|--|----------------|------------|---------------------------|---|----------------|------------|---------------------------|
| ASTM D-1655 Type A, A-1, JP-5,<br>and JP-8<br>(0.815 Kg/L) |                |            |                           | ASTM D-1655 Type B and JP-4<br>(0.779 Kg/L) |                |            |                           |
| Quantity<br>(Liters)                                       | Weight<br>(Kg) | CG<br>(MM) | Moment<br>(Kg-<br>MM/100) | Quantity<br>(Liters)                        | Weight<br>(Kg) | CG<br>(MM) | Moment<br>(Kg-<br>MM/100) |
| 40   | 32.6           | 3655       | 1191.5                    | 40  | 31.2           | 3655       | 1140.4                    |
| 80   | 65.2           | 3658       | 2385.0                    | 80  | 62.3           | 3658       | 2278.9                    |
| 120  | 97.8           | 3561       | 3482.7                    | 120   | 93.5           | 3561       | 3329.5                    |
| 160  | 130.4          | 3421       | 4461.0                    | 160   | 124.6          | 3421       | 4262.6                    |
| 200  | 163.0          | 3340       | 5444.2                    | 200   | 155.8          | 3340       | 5203.7                    |
| 240  | 195.6          | 3284       | 6423.5                    | 240   | 187.0          | 3284       | 6141.1                    |
| 280  | 228.2          | 3246       | 7407.4                    | 280   | 218.1          | 3246       | 7079.5                    |
| *297.1   | 242.1          | 3233       | 7827.1                    | *297.1                                      | 231.4          | 3233       | 7481.2                    |
| 320  | 260.8          | 3249       | 8473.4                    | 320   | 249.3          | 3249       | 8099.8                    |
| 360  | 293.4          | 3343       | 9808.4                    | 360   | 280.4          | 3343       | 9373.8                    |
| 400  | 326.0          | 3434       | 11194.8                   | 400   | 311.6          | 3434       | 10700.3                   |
| 440  | 358.6          | 3515       | 12604.8                   | 440   | 342.8          | 3515       | 12049.4                   |
| 480  | 391.2          | 3579       | 14001.1                   | 480   | 373.9          | 3579       | 13381.9                   |
| 520  | 423.8          | 3635       | 15405.1                   | 520   | 405.1          | 3635       | 14725.4                   |
| 560  | 456.4          | 3683       | 16809.2                   | 560   | 436.2          | 3683       | 16065.3                   |
| 600  | 489.0          | 3721       | 18195.7                   | 600   | 467.4          | 3721       | 17392.0                   |
| 640  | 521.6          | 3757       | 19596.5                   | 640   | 498.6          | 3757       | 18732.4                   |
| 680  | 554.2          | 3790       | 21004.2                   | 680   | 529.7          | 3790       | 20075.6                   |
| 720  | 586.8          | 3818       | 22404.0                   | 720   | 560.9          | 3818       | 21415.2                   |
| 760  | 619.4          | 3843       | 23803.5                   | 760   | 592.0          | 3843       | 22750.6                   |
| 800  | 652.0          | 3866       | 25206.3                   | 800   | 623.2          | 3866       | 24092.9                   |
| 827.4  | 674.3          | 3876       | 26135.9                   | 827.4                                       | 644.5          | 3876       | 24980.8                   |

\* Most critical fuel amount for most forward flight condition.

Note: All data above represents usable fuel based on nominal density at 15°C (59°F)

• COPYRIGHT © 2007 BY EAGLE COPTERS MAINTENANCE LTD •

This document is private and confidential and is supplied on the express condition that it is not to be used for any purpose or copied or communicated to any other person without written permission from Eagle Copters Maintenance Ltd.

Table 5-13 – Required Equipment Table  
Required Equipment Table

| Item                           | Weight<br>Lbs/Kg | Longitudinal<br>Arm<br>In./MM | Lateral Arm<br>(- Left, +<br>Right)<br>In./MM |
|--------------------------------|------------------|-------------------------------|---|
| <b>Indicators</b>              |                  |                               |   |
| Attitude                       | 5.3/2.4          | 23.0/584                      | +17.4/+442                                    |
| Airspeed                       | 0.8/0.4          | 23.0/584                      | +13.0/+330                                    |
| Vertical Speed                 | 1.8/0.8          | 24.0/610                      | +21.5/+546                                    |
| Altimeter                      | 1.5/0.7          | 23.0/584                      | +21.5/+546                                    |
| Turn And Slip                  | 1.9/0.9          | 23.0/584                      | +13.0/+330                                    |
| Transmission Oil Pressure      | 0.5/0.2          | 24.0/610                      | +0.5/+13                                      |
| Transmission Oil Temperature   | 0.7/0.3          | 24.0/610                      | +2.5/+64                                      |
| Engine Oil Pressure            | 0.5/0.2          | 23.3/592                      | +0.5/+13                                      |
| Engine Oil Temperature         | 0.7/0.3          | 23.4/594                      | +2.5/+64                                      |
| Dual Tachometer                | 1.9/0.9          | 23.0/584                      | +8.5/+216                                     |
| Fuel Pressure                  | 0.6/0.3          | 23.0/584                      | +0.5/+13                                      |
| Fuel Quantity                  | 0.6/0.3          | 23.0/584                      | +2.5/+64                                      |
| Gas Producer Tachometer        | 0.8/0.4          | 24.4/620                      | +8.5/+216                                     |
| MGT/EGT                        | 0.7/0.3          | 25.3/643                      | +8.5/+216                                     |
| Torque Pressure                | 0.5/0.2          | 24.0/610                      | +8.5/+216                                     |
| Standby Compass                | 0.8/0.4          | 24.5/622                      | +23.5/+597                                    |
| Clock                          | 0.5/0.2          | 25.0/635                      | +21.5/+546                                    |
| Free Air Temperature           | 0.7/0.3          | 25.0/635                      | +13.0/+330                                    |
| DC Voltmeter                   | 0.6/0.3          | 25.5/648                      | +2.8/+71                                      |
| AC Voltmeter                   | 0.6/0.3          | 26.1/663                      | +2.8/+71                                      |
| Fire Warning                   | 0.3/0.1          | 24.0/610                      | +0.6/+15                                      |
| Low Fuel Warning – Master      | 3.4/1.5          | 29.0/737                      | +2.5/+64                                      |
| Caution Panel (D212-725-7-017) |                  |                               |   |
| Low Fuel Warning – Master      | 1.75/0.8         | 29.0/737                      | +2.5/+64                                      |
| Caution Panel (D212-725-7-019) |                  |                               |   |
| Fire Extinguisher Switches     | 0.2/0.1          | 24.0/610                      | +0.6/+15                                      |
| Starter- Generator             | 48.0/21.8        | 185.0/4699                    | 0/0   |
| Battery                        | 80.0/36.3        | 3.9/99                        | -4.0/-102                                     |
| Starter Trigger Switch         | 0.1/neg.         | 31.0/787                      | +10.5/+267                                    |
| Anti-Collision Light, Upper    | 2.0/0.9          | 218.0/5537                    | 0/0   |
| Anti-Collision Light, Lower    | 2.0/0.9          | 65.4/1661                     | 0/0   |
| Landing Light                  | 4.3/2.0          | 84.6/2149                     | -4.2/-107                                     |

• COPYRIGHT © 2007 BY EAGLE COPTERS MAINTENANCE LTD •

This document is private and confidential and is supplied on the express condition that it is not to be used for any purpose or copied or communicated to any other person without written permission from Eagle Copters Maintenance Ltd.

Required Equipment Table

| Item                                   | Weight<br>Lbs/Kg | Longitudinal<br>Arm<br>In./MM | Lateral Arm<br>(- Left, +<br>Right)<br>In./MM |
|--|------------------|-------------------------------|---|
| Searchlight                            | 5.5/2.5          | 47.1/1196                     | +18.0/+457                                    |
| Position Lights                        |                  |                               |   |
| Forward Lower                          | 0.3/0.1          | 66.8/1697                     | 0/0   |
| Forward Upper                          | 0.3/0.1          | 109.2/2774                    | 0/0   |
| Aft                                    | 0.3/0.1          | 431.9/10970                   | 0/0   |
| Circuit Breaker Panels                 | 4.5/2.0          | 58.2/1478                     | 0/0   |
| Non-Essential Bus Switch               | 0.1/neg.         | 49.7/1262                     | +2.4/+61                                      |
| Essential Bus                          |                  |                               |   |
| Right Hand Overhead Control Panel      | 2.9/1.3          | 46.0/1168                     | +3.1/+79                                      |
| Left Hand Overhead Control Panel       | 2.3/1.0          | 54.4/1153                     | -3.0/-76                                      |
| Low Fuel Warning Transmitter           | 0.1/neg.         | 143.0/3632                    | 0/0   |
| VHF No.1 Radio                         |                  |                               |   |
| Transceiver And Mount                  | 4.3/2.0          | 7.4/188                       | +4.5/+114                                     |
| Control                                | 1.5/0.7          | 38.5/978                      | +2.5/+64                                      |
| Antenna                                | 0.5/0.2          | 47.0/1194                     | 0/0   |
| Windshield Wiper                       |                  |                               |   |
| Blade And Arm                          | 1.6/0.7          | 34.0/864                      | 0/0   |
| Motor                                  | 4.2/1.9          | 41.0/1041                     | 0/0   |
| Fire Extinguisher, Hand Type Left Hand | 8.0/3.6          | 72.0/1041                     | -35.0/-889                                    |
| Fire Extinguisher Hand Type Right Hand | 8.0/3.6          | 54.0/1372                     | +34.0/+864                                    |
| Safety Belt And Harness – Pilot        | 2.7/1.2          | 47.0/1194                     | +22.0/+559                                    |
| Safety Belt And Harness – Copilot      | 2.7/1.2          | 47.0/1194                     | -22.0/-559                                    |
| Flight Manual                          | 1.7/0.8          | -/-                           | -/-   |

• COPYRIGHT © 2007 BY EAGLE COPTERS MAINTENANCE LTD •

This document is private and confidential and is supplied on the express condition that it is not to be used for any purpose or copied or communicated to any other person without written permission from Eagle Copters Maintenance Ltd.

Unapproved

Revision: **M**

Date: 2026-04-13

## 5.8 Optional System Descriptions

### 5.8.1 USB Charging Ports

Dedicated dual USB charging ports may be installed in the centre pedestal, as well as the aft face of the door posts for use in the cabin. These ports provide charging to personal devices and have no data connectivity.

| Dual USB Port Configuration    | Circuit Breaker | Location                 |
|--------------------------------|-----------------|--------------------------|
| USB-C/C Upper<br>USB-A/C Lower | USB LH AFT      | Aft face of LH door post |
| USB-C/C Upper<br>USB-A/C Lower | USB RH AFT      | Aft face of RH door post |
| USB-A/C Left<br>USB-A/C Right  | USB FWD         | Center pedestal          |

### 5.8.2 Dual Digital Clocks with USB Charging Ports

Dual CH93 Mid Continent digital clocks with USB charging ports may be installed in the instrument panel. The USB ports provide charging to personal devices and have no data connectivity.

| USB Port Configuration | Circuit Breaker | Location            |
|------------------------|-----------------|---------------------|
| USB-A/A                | PILOT CLOCK     | RH instrument panel |
| USB-A/A                | COPILOT CLOCK   | LH instrument panel |

• COPYRIGHT © 2007 BY EAGLE COPTERS MAINTENANCE LTD •

This document is private and confidential and is supplied on the express condition that it is not to be used for any purpose or copied or communicated to any other person without written permission from Eagle Copters Maintenance Ltd.



# Appendix A

## Table of Contents

A.1 Optional Equipment.....A-2

## List of Tables

Table A-1 – Flight Manual Supplements for Optional Equipment.....A-2

• COPYRIGHT © 2007 BY EAGLE COPTERS MAINTENANCE LTD •

This document is private and confidential and is supplied on the express condition that it is not to be used for any purpose or copied or communicated to any other person without written permission from Eagle Copters Maintenance Ltd.

# Appendix A

## A.1 Optional Equipment

When the following optional equipment is installed on the helicopter, the applicable Flight Manual Supplement for each kit listed in Table A-1 must be carried in the helicopter at all times.

Table A-1 – Flight Manual Supplements for Optional Equipment

| NAME OF EQUIPMENT   | DATE CERTIFIED | CURRENT REVISION |
|---|----------------|------------------|
| FMS-D212-725-2<br>T5317A High Performance Utility Data<br>with the BLR Fast Fin Installed | 19.02.15       | Rev. A           |
| FMS-D212-725-3<br>T5317A Additional Performance Data<br>with the BLR Fast Fin Installed   | 19.02.15       | Rev. A           |
| FMS-D212-725-4<br>T5317B High Performance Utility Data<br>with the BLR Fast Fin Installed | 19.02.15       | Rev. A           |

• COPYRIGHT © 2007 BY EAGLE COPTERS MAINTENANCE LTD •

This document is private and confidential and is supplied on the express condition that it is not to be used for any purpose or copied or communicated to any other person without written permission from Eagle Copters Maintenance Ltd.